

# System 12RLFCC Submittal

**AOU12RLFC, AUU12RLF**

## Compact Cassette

Job Name: \_\_\_\_\_ Approval: \_\_\_\_\_ Date: \_\_\_\_\_  
 Location: \_\_\_\_\_ Construction: \_\_\_\_\_  
 Engineer: \_\_\_\_\_ Unit #: \_\_\_\_\_  
 Submitted to: \_\_\_\_\_ Drawing #: \_\_\_\_\_  
 Submitted by: \_\_\_\_\_ Reference: \_\_\_\_\_



**Outdoor Unit Power** 208-230VAC-1Ph-60Hz  
 Available Voltage Range 187-253VAC  
 Fuse Size, Max. 15A  
 MCA 13.4A

**Compressor** Inverter Driven Variable Speed DC Rotary  
 No. used 1  
 Output 850W  
 Lubrican Oil POE (RB68)

**Fan type** Propeller  
 Motor Output 115W  
 Airflow Rate Cooling/Heating (High) 1206 / 1083CFM

**Refrigerant** 410A  
 Outdoor Unit 2lbs 10oz  
 Control Electronic Expansion Valve  
 O.D. Discharge (in) 1/4"(Flare)  
 O.D Suction (in) 3/8"(Flare)

**Dimensions** H x W x D  
 Uncrated (in) 24-1/2 x 31-3/32 x 11-11/32  
 (mm) (620 x 790 x 290)  
 Crated (in) 28-1/16 x 37-7/32 x 15-9/16  
 (mm) (713 x 945 x 395)

**Weight** Outdoor  
 Net 84lbs (38kg)  
 Gross Shipping 93lbs (42kg)

**Cooling**  
 Rated Capacity 12,000BTU/h  
 Min-Max Capacity 3,100~13,600BTU/h  
 Rated Power Input 0.94kw  
 Max. Power Input 1.45kw  
 SEER 21.9  
 EER 12.8  
 Outdoor Sound Rating 49dB

**Heating**  
 Rated Capacity 16,000BTU/h  
 Min-Max Capacity 3,100~19,400BTU/h  
 Rated Power Input 1.44kw  
 Max. Power Input 2.00kw  
 HSPF 12.2  
 EER 11.1  
 Outdoor Sound Rating 50dB

**Piping Lengths**  
 Max. Piping Length (Total) 66ft  
 Max. Pipe Height Difference 49ft  
 Connection method (Flared)

**Operating Range**  
 Cooling 14°F~115°F DB  
 Heating -5°F~75°F DB

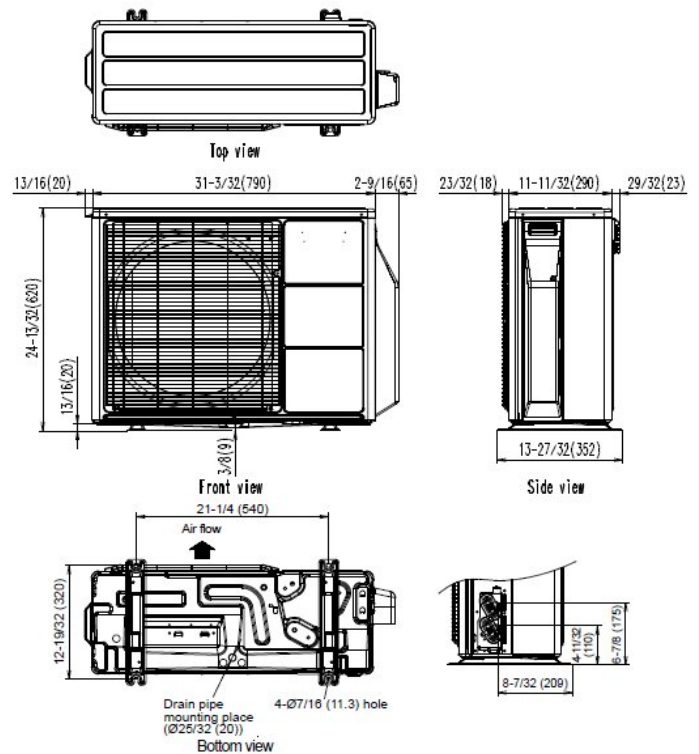

Fujitsu General America, Inc.  
 Fairfield, NJ 07004  
 Toll Free: 1-888-888-3424  
 Fax: (973) 836-0447  
 www.fujitsugeneral.com

Fujitsu products are subject to continuous improvements. Fujitsu reserves the right to modify product design, specifications and information in this data sheet without notice and without incurring any obligations.



<b>Power</b>	V/Hz/P	230/60/1
<b>Fan type</b>		Turbo
No. Motors	(W)	42-1
CFM	(Hi,Me,Lo,Qu)	359/312/277/241
Sound Pressure Level	db (Hi,Me,Lo,Qu)	37/33/31/28
F.L.A.	(A)	.19
<b>Refrigerant</b>		410A
O.D. Discharge	in (mm)	1/4"(6.35)
O.D. Suction	in (mm)	3/8"(9.52)
<b>Dimensions</b>		H x W x D
Unit Uncrated	(in)	9-21/32 x 22-14/32 x 22-14/32
	(mm)	(245x570x570)
Unit Crated	(in)	10-7/16 x 28-3/4 x 24-19/32
	(mm)	(265x730x625)
Panel Uncrated	(in)	1-15/16 x 27-9/16 x 27-9/16
	(mm)	(49x700x700)
Panel Crated	(in)	4-23/32 x 30-1/8 x 29-23/32
	(mm)	(120x765x755)
<b>Weight</b>		
Unit Net	lbs. (kg)	33 (15)
Unit Gross Shipping	lbs. (kg)	40 (18)
Panel Net	lbs. (kg)	5.7 (2.6)
Panel Gross Shipping	lbs. (kg)	10 (4.5)

<b>Cooling Capacity</b>	(BTU/h)	12,000
<b>Moisture Removal</b>	pt/h (l/h)	2.5 (1.2)
<b>Heating Capacity</b>	(BTU/h)	16,000
<b>Temperature Setting Range</b>		
Cooling	°F(°C)	64~90 (18~32)
Heating	°F(°C)	60~88 (16~31)
<b>Drain Pipe Size</b>	OD in (mm)	Ø1 (25.4)
	ID in (mm)	Ø3/4 (19.4)
<b>Condensate Pump Lift*</b>	in (mm)	28 (700)
<b>Remote Control Type</b>		Wired (Wireless Optional)
<b>Electrical Connection**</b>	AWG	14/3 with ground

\*Pump is capable of providing 28" of lift at no more than 6" away from the unit. Lift is measured from the suction of the pump which is located at the bottom of the unit and not the outlet of the condensate.

\*\*Power and communication are fed from the outdoor unit.

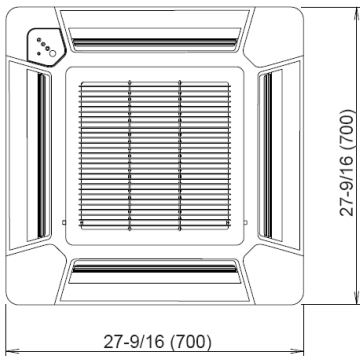

Grille  
(sold separately)

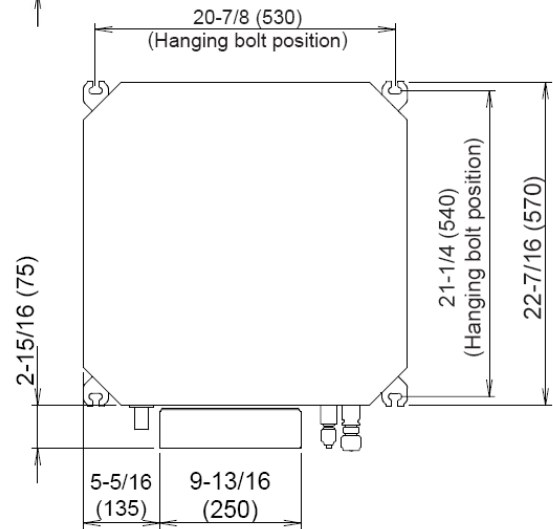
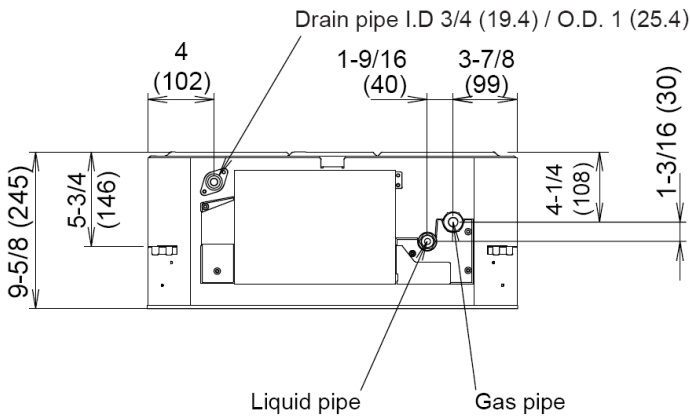
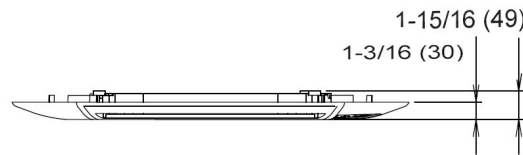

**Note:**

Specifications are based on the following conditions.

Power source of specifications : 230V

Cooling: Indoor temperature of 80°F(26.67°C)DB / 67°F(19.44°C)WB, and outdoor temperature of 95°F(35°C)DB/75°F(23.89°C)WB.

Heating: Indoor temperature of 70°F(21.11°C)DB / 60°F(15.56°C)WB, and outdoor temperature of 47°F(8.33°C)DB/43°F(6.11°C)WB.

Standard Static Pressure: 0.10in.WG (25Pa)

Pipe length : 16.4ft. (5m) [Outdoor unit - Branch box], 9.8ft. (3m) [Branch box - Indoor unit]

Height difference : 0 ft.(0m) [Outdoor unit - Indoor unit]

Fujitsu General America, Inc.  
Fairfield, NJ 07004  
Toll Free: 1-888-888-3424  
Fax: (973) 836-0447  
www.fujitsugeneral.com

Fujitsu products are subject to continuous improvements. Fujitsu reserves the right to modify product design, specifications and information in this data sheet without notice and without incurring any obligations.

