

# AIR CONDITIONER

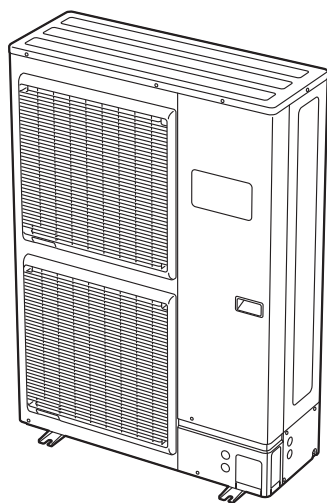

## INSTALLATION MANUAL

OUTDOOR UNIT

For authorized service personnel only.

English

## MANUEL D'INSTALLATION

APPAREIL EXTÉRIEUR

Pour le personnel d'entretien autorisé uniquement.

Français

## MANUAL DE INSTALACIÓN

UNIDAD EXTERIOR

Únicamente para personal de servicio autorizado.

Español



PART No. 9379069908-03

# INSTALLATION MANUAL

PART No. 9379069908-03  
OUTDOOR UNIT

## Contents

1. SAFETY PRECAUTIONS.....	1
1.1. IMPORTANT! Please read before starting.....	1
1.2. Special precautions.....	1
2. ABOUT THIS PRODUCT.....	2
2.1. Precautions for using R410A refrigerant.....	2
2.2. Special tools for R410A refrigerant.....	2
2.3. Accessories.....	2
2.4. Optional parts.....	2
2.5. Operating range.....	2
3. GENERAL SPECIFICATION.....	3
3.1. Selecting circuit breaker and wiring.....	3
3.2. Selecting the pipe material.....	3
3.3. Protection of pipes.....	3
3.4. Refrigerant pipe size and allowable piping length.....	3
3.5. For Pre-charge lengths.....	3
3.6. If additional refrigerant is required.....	3
4. INSTALLATION WORK.....	3
4.1. Selecting an installation location.....	3
4.2. Installation dimensions.....	4
4.3. Transporting the unit.....	5
4.4. Drain installation.....	5
4.5. Secure the unit.....	5
5. PIPE INSTALLATION-1.....	5
5.1. Opening a knock out hole.....	5
5.2. Brazing.....	6
5.3. Flare connection (pipe connection).....	6
5.4. Sealing test.....	7
5.5. Vacuum process.....	7
5.6. Additional charging.....	7
6. ELECTRICAL WIRING.....	8
6.1. Notes for electrical wiring.....	8
6.2. Knock out holes for wiring.....	8
6.3. Wiring method.....	8
7. PIPE INSTALLATION-2.....	9
7.1. Installing insulation.....	9
7.2. Filling with putty.....	9
8. HOW TO OPERATE DISPLAY UNIT.....	10
8.1. Display unit position.....	10
8.2. Description of display and button.....	10
9. FIELD SETTING.....	10
9.1. Field setting buttons.....	10
9.2. Function settings.....	10
10. EXTERNAL INPUT AND OUTPUT.....	12
10.1. External input.....	12
10.2. External output.....	12
10.3. Connection method.....	12
11. TEST RUN.....	13
11.1. Pre-test run check items.....	13
11.2. Test operation method.....	13
11.3. Check list.....	13
12. ERROR CODE.....	14
12.1. Error display mode.....	14
12.2. Error code check table.....	14
13. PUMP DOWN.....	15
13.1. Preparation for pump down.....	15
13.2. Pump down procedure.....	15

**NOTES:** This manual describes how to install the air conditioner described above.  
Handling and installation shall only be done by professionals as outlined in this manual.

- Installation must be performed in accordance with the requirement of NEC (National Electrical Code) and CEC (Canadian Electrical Code) by authorized personnel only.
- All products are manufactured to metric units and tolerances. United States customary units are provided for reference only. In cases where exact dimensions and tolerances are required, always refer to metric units.

## 1. SAFETY PRECAUTIONS

### 1.1. IMPORTANT! Please read before starting

This air conditioning system meets strict safety and operating standards.  
As the installer or service person, it is an important part of your job to install or service the system so it operates safely and efficiently.

**For safe installation and trouble-free operation, you must:**

- Carefully read this instruction booklet before beginning.
- Follow each installation or repair step exactly as shown.
- Observe all local, state, and national electrical codes.
- Pay close attention to all warning and caution notices given in this manual.

**WARNING:** This symbol refers to a hazard or unsafe practice which can result in severe personal injury or death.

**CAUTION:** This symbol refers to a hazard or unsafe practice which can result in personal injury and the potential for product or property damage.

- Hazard alerting symbols



: Electrical



: Safety/alert

### If Necessary, Get Help

These instructions are all you need for most installation sites and maintenance conditions. If you require help for a special problem, contact our sales/service outlet or your certified dealer for additional instructions.

### In Case of Improper Installation

The manufacturer shall in no way be responsible for improper installation or maintenance service, including failure to follow the instructions in this document.

## 1.2. Special precautions

### When Wiring

**ELECTRICAL SHOCK CAN CAUSE SEVERE PERSONAL INJURY OR DEATH. ONLY A QUALIFIED, EXPERIENCED ELECTRICIAN SHOULD ATTEMPT TO WIRE THIS SYSTEM.**

- Do not supply power to the unit until all wiring and tubing are completed or reconnected and checked.
- Highly dangerous electrical voltages are used in this system. Carefully refer to the wiring diagram and these instructions when wiring. Improper connections and inadequate earthing (grounding) can cause accidental injury or death.
- Earth (Ground) the unit following local electrical codes.
- Connect all wiring tightly. Loose wiring may cause overheating at connection points and a possible fire hazard.

### When Transporting

Be careful when picking up and moving the indoor and outdoor units. Get a partner to help, and bend your knees when lifting to reduce strain on your back. Sharp edges or thin aluminum fins on the air conditioner can cut your fingers.

### When Installing...

#### ...In a Ceiling or Wall

Make sure the ceiling/wall is strong enough to hold the unit's weight. It may be necessary to construct a strong wood or metal frame to provide added support.

#### ...In a Room

Properly insulate any tubing run inside a room to prevent "sweating" that can cause dripping and water damage to walls and floors.

#### ...In Moist or Uneven Locations

Use a raised concrete pad or concrete blocks to provide a solid, level foundation for the outdoor unit. This prevents water damage and abnormal vibration.

#### ...In an Area with High Winds

Securely anchor the outdoor unit down with bolts and a metal frame.  
Provide a suitable air baffle.

#### ...In a Snowy Area (for Heat Pump-type Systems)

Install the outdoor unit on a raised platform that is higher than drifting snow.

### When Connecting Refrigerant Tubing

- Keep all tubing runs as short as possible.
- Use the flare method for connecting tubing.
- Apply refrigerant lubricant to the matching surfaces of the flare and union tubes before connecting them, then tighten the nut with a torque wrench for a leak-free connection.
- Check carefully for leaks before opening the refrigerant valves.

### NOTES:

Depending on the system type, liquid and gas lines may be either narrow or wide. Therefore, to avoid confusion the refrigerant tubing for your particular model is specified as either "small" or "large" rather than as "liquid" or "gas".

### When Servicing

- Turn the power OFF at the main circuit breaker panel before opening the unit to check or repair electrical parts and wiring.
- Keep your fingers and clothing away from any moving parts.
- Clean up the site after you finish, remembering to check that no metal scraps or bits of wiring have been left inside the unit being serviced.
- After installation, explain correct operation to the customer, using the operating manual.

### WARNING

Never touch electrical components immediately after the power supply has been turned off. Electrical shock may occur. After turning off the power, always wait 10 minutes or more before touching electrical components.

- Be sure to read this manual thoroughly before installation.
- The warnings and precautions indicated in this Manual contain important information pertaining to your safety. Be sure to observe them.
- Hand this Manual, together with the operating manual, to the customer. Request the customer to keep them on hand for future use, such as for relocating or repairing the unit.

### WARNING

- Installation of this product must be done by experienced service technicians or professional installers only in accordance with this manual. Installation by non-professional or improper installation of the product may cause serious accidents such as injury, water leakage, electric shock, or fire.  
If the outdoor unit is installed in disregard of the instructions in the installation manual, it will void the manufacturer's warranty.
- Do not turn on the power until all work has been completed. Turning on the power before the work is completed can cause serious accidents such as electric shock or fire.
- If refrigerant leaks when you are working, ventilate the area. If the leaking refrigerant is exposed to a direct flame, it may produce a toxic gas.

- Installation work must be performed in accordance with regulations, codes, or standards for electrical wiring and equipment in each country, region, or the installing place.
- Do not use this equipment with air or any other unspecified refrigerant in the refrigerant lines. Excess pressure can cause a rupture.
- During installation, make sure that the refrigerant pipe is attached firmly before you run the compressor. Do not operate the compressor under the condition of refrigerant piping not attached properly with 3-way valve open. This may cause abnormal pressure in the refrigeration cycle that leads to rupture and even injury.
- When installing and relocating the air conditioner, do not mix gases other than the specified refrigerant (R410A) to enter the refrigerant cycle. If air or other gas enters the refrigerant cycle, the pressure inside the cycle will rise to an abnormally high value and cause rupture, injury, etc.
- For the air conditioner to work appropriately, install it as written in this manual.
- To connect the indoor unit and outdoor unit, use air conditioner piping and cables available locally as standard parts. This manual describes proper connections using such installation set.
- Do not use an extension cable.
- Do not purge the air with refrigerants but use a vacuum pump to vacuum the installation.
- There is no extra refrigerant in the outdoor unit for air purging.
- Using the same vacuum pump for different refrigerants may damage the vacuum pump or the unit.
- Use a clean gauge manifold, vacuum pump and charging hose for R410A exclusively.
- During the pump-down operation, make sure that the compressor is turned off before you remove the refrigerant piping. Do not remove the connection pipe while the compressor is in operation with 3-way valve open. This may cause abnormal pressure in the refrigeration cycle that leads to rupture and even injury.
- Dispose of the packing materials safely. Tear and dispose of the plastic packing bags so that children cannot play with them. There is the danger of suffocation if children play with the original plastic bags.
- This appliance is not intended for use by persons (including children) with reduced physical, sensory or mental capabilities, or lack of experience and knowledge, unless they have been given supervision or instruction concerning use of the appliance by a person responsible for their safety. Children should be supervised to ensure that they do not play with the appliance.
- Cancer and Reproductive Harm - www.P65Warnings.ca.gov

### ⚠ CAUTION

- This unit must be installed by qualified personnel with a capacity certification of handling refrigerant fluids. Refer to regulation and laws in use on installation place.
- Install the unit by following local codes and regulations in force in the place of installation, and the installation instructions of the manufacturer.
- This unit is part of a set constituting an air conditioner. The unit must not be installed alone or be installed with device not authorized by the manufacturer.
- Always use a separate power supply line protected by a circuit breaker operating on all wires with a distance between contact of 3mm for this unit.
- To protect the persons, earth (ground) the unit correctly, and use the power cable combined with an Earth Leakage Circuit Breaker (ELCB).
- The units are not explosion proof, and therefore should not be installed in explosive atmosphere.
- This unit contains no user-serviceable parts. Always consult experienced service technician for repairing.
- When moving or relocating the air conditioner, consult experienced service technicians for disconnection and installation of the unit.
- Children should be monitored to ensure they do not play with the device.
- Do not touch the aluminum fins of heat exchanger built-in the indoor or outdoor unit to avoid personal injury when you install or maintain the unit.
- Do not place any other electrical products or household belongings under indoor unit or outdoor unit. Dripping condensation from the unit might get them wet, and may cause damage or malfunction of your property.

## 2. ABOUT THIS PRODUCT

### 2.1. Precautions for using R410A refrigerant

#### ⚠ WARNING

- Do not introduce any substance other than the prescribed refrigerant into the refrigeration cycle. If air enters the refrigeration cycle, the pressure in the refrigeration cycle will become abnormally high and cause the piping to rupture.
- If there is a refrigerant leak, make sure that it does not exceed the concentration limit. If a refrigerant leak exceeds the concentration limit, it can lead to accidents such as oxygen starvation.
- Do not touch refrigerant that has leaked from the refrigerant pipe connections or other areas. Touching the refrigerant directly can cause frostbite.
- If a refrigerant leak occurs during operation, immediately vacate the premises and thoroughly ventilate the area. If the refrigerant comes in contact with a flame, it produces a toxic gas.
- The basic installation work procedures are the same as conventional refrigerant models. However, pay careful attention to the following points:
  - Since the working pressure is 1.6 times higher than that of conventional refrigerant (R22) models, some of the piping and installation and service tools are special. (See the table below.) Especially, when replacing a conventional refrigerant (R22) model with a new refrigerant R410A model, always replace the conventional piping and flare nuts with the R410A piping and flare nuts.
  - Models that use refrigerant R410A have a different charging port thread diameter to prevent erroneous charging with conventional refrigerant (R22) and for safety. Therefore, check beforehand. [The charging port thread diameter for R410A is 1/2-20 UNF.]

- Be careful that foreign matter (oil, water, etc.) does not enter the piping than with refrigerant models. Also, when storing the piping, securely seal the openings by pinching, taping, etc.
- When charging the refrigerant, take into account the slight change in the composition of the gas and liquid phases. And always charge from the liquid phase where refrigerant composition is stable.

### 2.2. Special tools for R410A refrigerant

#### ⚠ WARNING

To install a unit that uses R410A refrigerant, use dedicated tools and piping materials that have been manufactured specifically for R410A use. Because the pressure of R410A refrigerant is approximately 1.6 times higher than R22, failure to use dedicated piping material or improper installation can cause rupture or injury. Furthermore, it can cause serious accidents such as water leakage, electric shock, or fire.





Tool name	Changes
Gauge manifold	Pressure is high and cannot be measured with a conventional gauge. To prevent erroneous mixing of other refrigerants, the diameter of each port has been changed. It is recommended the gauge with seals -0.1 to 5.3 MPa (-1 to 53 bar) for high pressure. -0.1 to 3.8 MPa (-1 to 38 bar) for low pressure.
Charging hose	To increase pressure resistance, the hose material and base size were changed.
Vacuum pump	A conventional vacuum pump can be used by installing a vacuum pump adapter.
Gas leakage detector	Special gas leakage detector for HFC refrigerant R410A.

### 2.3. Accessories

#### ⚠ WARNING

For installation purposes, be sure to use the parts supplied by the manufacturer or other prescribed parts. The use of non-prescribed parts can cause serious accidents such as the unit falling, water leakage, electric shock, or fire.

Following installation parts are supplied. Use them as required. Keep this manual in a safe place, and do not discard any other accessories until the installation work has been completed.

Name and shape	Q'ty	Description
Installation manual 	1	This manual
Drain pipe 	1	To Drain installation (Reverse cycle model only)
Drain cap 	5	To Drain installation
Washer 	1	If conduit holes do not fit, please use a washer.

### 2.4. Optional parts

Parts name	Model name
External connect kit (for External input/output)	UTY-XWZX3

### 2.5. Operating range

Outdoor	Cooling/Dry Mode	Heating Mode
Temperature	-5 to 115°F (-20 to 46°C)	-5 to 75°F (-20 to 24°C)

- If operated at a temperature beyond the specified operating range, a protection circuit may be activated to stop the operation of the unit.

### 3. GENERAL SPECIFICATION

#### 3.1. Selecting circuit breaker and wiring

##### ⚠ CAUTION

- Be sure to install a breaker of the specified capacity.
- Regulation of cables and breaker differs from each locality, refer in accordance with local rules.

<b>Voltage rating</b>	1 ∅ 208/230 V (60 Hz)
<b>Operating range</b>	188-253 V

Cable	Cable size (AWG)	Cable type	Remark
Power supply cable	AWG 14 to 10	Sheathed PVC cable	2 wire + Earth (Ground)
Connection cable	AWG 18 to 16	Sheathed PVC cable	3 wire + Earth (Ground)

Select the correct cable type and size according to the country or region's regulations.  
Cable Length: Limit voltage drop to less than 2%. Increase cable gauge if voltage drop is 2% or more.

##### ⚠ CAUTION

MODEL	42	48
MINIMUM CIRCUIT AMPACITY	25.2 A	28.3A
MAX. CKT. BKR. (MAXIMUM CIRCUIT BREAKER)	30 A	30 A

- Before starting work check that power is not being supplied to all poles of the indoor unit and outdoor unit.
- Install all electrical works in accordance to the national standard.
- Install the disconnect device with a contact gap of at least 2/16 in (3 mm) in all poles nearby the units. (Both indoor unit and outdoor unit)
- Install the circuit breaker nearby the units.

#### 3.2. Selecting the pipe material

##### ⚠ CAUTION

- Do not use existing pipes.
- Use pipes that have clean external and internal sides without any contamination which may cause trouble during use, such as sulfur, oxide, dust, cutting waste, oil, or water.
- It is necessary to use seamless copper pipes.  
Material: Phosphor deoxidized seamless copper pipes.  
It is desirable that the amount of residual oil is less than 40 mg/33ft (10m).
- Do not use copper pipes that have a collapsed, deformed, or discolored portion (especially on the interior surface). Otherwise, the expansion valve or capillary tube may become blocked with contaminants.
- Improper pipe selection will degrade performance. As an air conditioner using R410A incurs pressure higher than when using conventional refrigerant, it is necessary to choose adequate materials.

##### NOTES:

Thicknesses of copper pipes used with R410A are as shown in the table.  
Never use copper pipes thinner than those indicated in the table even if they are available on the market.

##### Thicknesses of Annealed Copper Pipes (R410A)

Pipe outside diameter [in (mm)]	Thickness [in (mm)]
1/4 (6.35)	0.032 (0.80)
3/8 (9.52)	0.032 (0.80)
1/2 (12.70)	0.032 (0.80)
5/8 (15.88)	0.039 (1.00)
3/4 (19.05)	0.047 (1.20)

#### 3.3. Protection of pipes

Protect the pipes to prevent the entry of moisture and dust.  
Especially, pay attention when passing the pipes through a hole or connecting the end of a pipe to the outdoor unit.

Location	Working period	Protection method
Outdoor	1 month or more	Pinch pipes
	Less than 1 month	Pinch or tape pipes
Indoor	-	Pinch or tape pipes

#### 3.4. Refrigerant pipe size and allowable piping length

##### ⚠ CAUTION

Keep the piping length between the indoor unit and outdoor unit within the allowable tolerance.

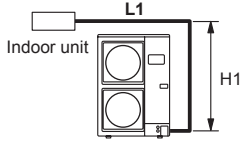
Pipe diameter <Liquid/Gas> (Standard) [in (mm)]	3/8 (9.52) / 5/8 (15.88)
Max. piping length (L1)	246 ft (75 m)
Min. piping length (L1)	16 ft (5 m)
Max. height difference (H1) <Indoor unit to outdoor unit>	98 ft (30 m)
View (Example)	

\*For the standard pipe diameter.

#### 3.5. For Pre-charge lengths

##### 3.5.1. For Pre-charge lengths

Piping length (L) *Pre-charge
66 ft ( 20m )

#### 3.6. If additional refrigerant is required

##### 3.6.1. If additional refrigerant is required

- When the piping is longer than pre-charge length, additional charging is necessary.
- For the additional amount, see the table below.

##### Additional charging amount

###### Single type

L1 > Pre-charge length

Piping length	66 ft (20 m)	98 ft (30 m)	131 ft (40 m)	165 ft (50 m)	196 ft (60 m)	230 ft (70 m)	246 ft (75 m)	Rate
Additional charge	None	14 oz (400 g)	1 lb 12 oz (800 g)	2 lb 10 oz (1200 g)	3 lb 8 oz (1600 g)	4 lb 7 oz (2000 g)	4 lb 14 oz (2200 g)	0.43 oz/ft (40 g/m)

### 4. INSTALLATION WORK

Make sure to obtain the customer's approval for selecting and installing the outdoor unit.

#### 4.1. Selecting an installation location

##### ⚠ WARNING

- Securely install the outdoor unit at a location that can withstand the weight of the unit. Otherwise, the outdoor unit may fall and cause injury.
- Be sure to install the outdoor unit as prescribed, so that it can withstand earthquakes and typhoons or other strong winds. Improper installation can cause the unit to topple or fall, or other accidents.
- Do not install the outdoor unit near the edge of a balcony. Otherwise, children may climb onto the outdoor unit and fall off of the balcony.

##### ⚠ CAUTION

- Do not install the outdoor unit in the following areas:
  - Area with high salt content, such as at the seaside. It will deteriorate metal parts, causing the parts to fail or the unit to leak water.
  - Area filled with mineral oil or containing a large amount of splashed oil or steam, such as a kitchen. It will deteriorate plastic parts, causing the parts to fail or the unit to leak water.
  - Area that generates substances that adversely affect the equipment, such as sulfuric gas, chlorine gas, acid, or alkali. It will cause the copper pipes and brazed joints to corrode, which can cause refrigerant leakage.
  - Area containing equipment that generates electromagnetic interference. It will cause the control system to malfunction, preventing the unit from operating normally.
  - Area that can cause combustible gas to leak, contains suspended carbon fibers or flammable dust, or volatile inflammables such as paint thinner or gasoline. If gas leaks and settles around the unit, it can cause a fire.
  - Area where small animals may live. It may cause failure, smoke or fire if small animals enter and touch internal electrical parts.
  - Area where animals may urinate on the unit or ammonia may be generated.
- Do not tilt the outdoor unit more than 3 degrees.
- Install the outdoor unit in a well-ventilated location away from rain or direct sunlight.
- If the outdoor unit must be installed in an area within easy reach of the general public, install as necessary a protective fence or the like to prevent their access.

- Install the outdoor unit in a location that would not inconvenience your neighbors, as they could be affected by the airflow coming out from the outlet, noise, or vibration. If it must be installed in proximity to your neighbors, be sure to obtain their approval.
- If the outdoor unit is installed in a cold region that is affected by snow accumulation, snow fall, or freezing, take appropriate measures to protect it from those elements. To ensure a stable operation, install inlet and outlet ducts.
- Install the outdoor unit in a location that is away from exhaust or the vent ports that discharge vapor, soot, dust, or debris.
- Install the indoor unit, outdoor unit, power supply cable, connection cable, and remote control cable at least 3.3ft (1m) away from a television or radio receivers. The purpose of this is to prevent TV reception interference or radio noise. (Even if they are installed more than 3.3ft (1m) apart, you could still receive noise under some signal conditions.)

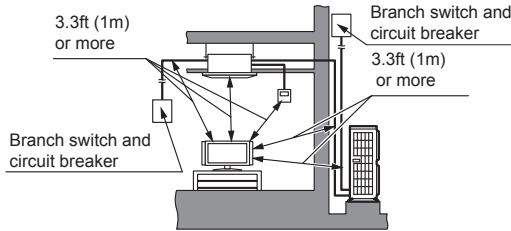

- If children under 10 years old may approach the unit, take preventive measures so that they cannot reach the unit.
- Keep the length of the piping of the indoor and outdoor units within the allowable range.
- For maintenance purposes, do not bury the piping.

## 4.2. Installation dimensions

### CAUTION

- The installation space shown in the following examples is based on an ambient temperature under cooling operation of 95°F (35°C) (DB) at the air intake of the outdoor unit. Provide more space around the air intake than shown in the examples if the ambient temperature exceeds 95°F (35°C) (DB) or if the thermal load of all of the outdoor units exceeds the capacity.
- Consider the transportation route, installation space, maintenance space, and access, and install the unit in a location with sufficient space for the refrigerant piping.
- Observe the installation space specifications that are shown in the figures. Keep the same space at rear air intake. Provide the same space for the air intake at the rear of the outdoor unit. If the installation is not performed according to the specifications, it could cause a short circuit and result in a lack of operating performance. As a result, the outdoor unit might easily be stopped by high-pressure protection.

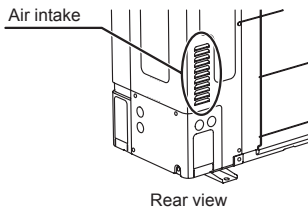

- Installation methods not shown in the following examples are not recommended. Performance may drop significantly.

### 4.2.1. Single outdoor unit installation

When the upward area is open [Unit: in (mm)]

(1) Obstacles at rear only

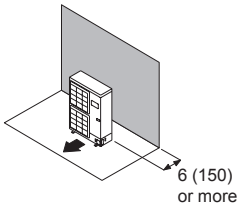

(2) Obstacles at rear and sides only

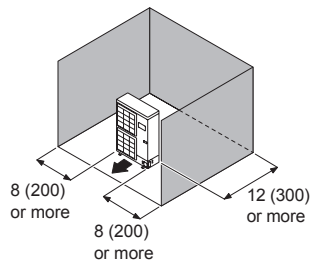

(3) Obstacles at front only

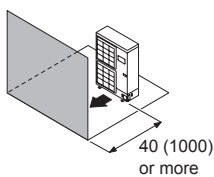

(4) Obstacles at front and rear only

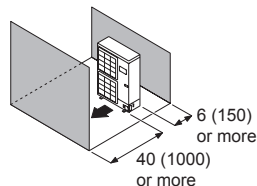

When an obstruction is present also in the upward area [Unit: in (mm)]

(1) Obstacles at rear and above only

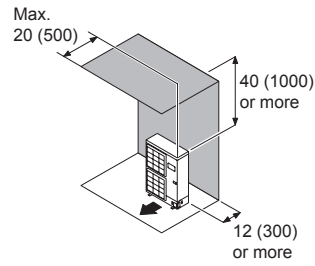

(2) Obstacles at rear, sides, and above only

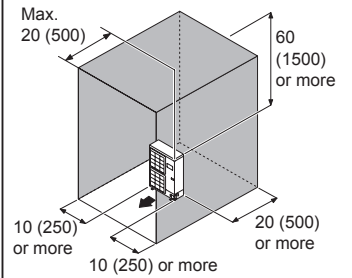

### 4.2.2. Multiple outdoor unit installation

- When routing the piping from the side of an outdoor unit, provide space for the piping.
- No more than 3 units must be installed side by side. When 3 units or more are arranged in a line, provide the space as shown in the following example when an obstruction is present also in the upward area.

When the upward area is open [Unit: in (mm)]

(1) Obstacles at rear only

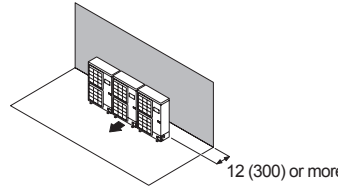

(2) Obstacles at front only

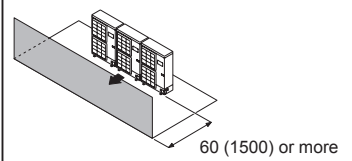

(3) Obstacles at front and rear only

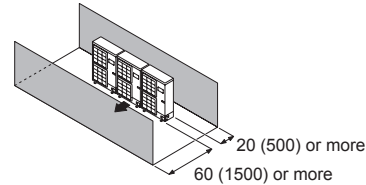

When an obstruction is present also in the upward area [Unit: in (mm)]

(1) Obstacles at rear and above only

- Up to 3 units can be installed side by side.
- When 4 units or more are arranged in a line, provide the space as shown below.

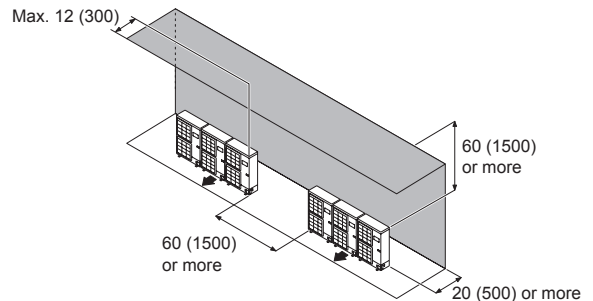

### 4.2.3. Outdoor units installation in multi row [Unit: in (mm)]

(1) Single parallel unit arrangement

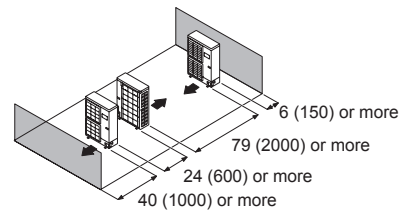

(2) Multiple parallel unit arrangement

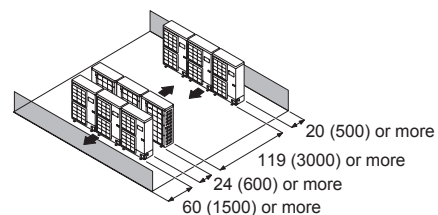

### NOTES:

- If the space is larger than stated above, the condition will be the same as when there is no obstacle.
- Height above the floor level should be 50 mm or more.
- When installing the outdoor unit, be sure to open the front and left side to obtain better operation efficiency.



### 4.3. Transporting the unit

#### ⚠ WARNING

Do not touch the fins.  
Otherwise, personal injury could result.

#### ⚠ CAUTION

When carrying the unit, hold the handles on the right and left sides and be careful.  
If the outdoor unit is carried from the bottom, hands or fingers may be pinched.

- Carry slowly in the manner as shown on "Fig. B" holding the handles "Fig. A" in right and left sides. (Be careful not to touch with hands or objects.)
- Be sure to hold the handles on the sides of the unit. Otherwise, the suction grilles on the sides of the unit may be deformed.

Fig. A

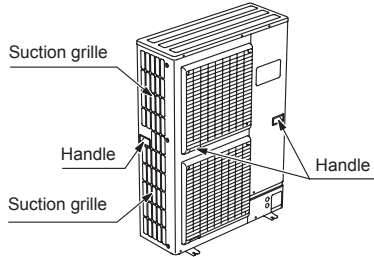
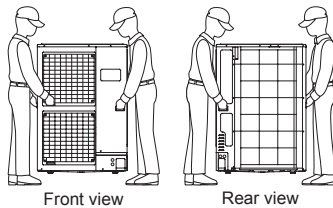

Fig. B



### 4.4. Drain installation

#### ⚠ CAUTION

- In places where the outdoor temperature drops to 32 °F (0 °C) or lower, the drain water may freeze and may stop up the drain or cause other outdoor unit trouble. Therefore take measures so that the drain water will not freeze and clog the drain.
- Please set up the outdoor unit in a high place and please do not arrange the frame of installed stand under the drain port, because the water dropped from the drain port repeats freezing and accumulating, and may block the drain port.
- In the area with heavy snowfall, if the intake and outlet of outdoor unit is blocked with snow, it might become difficult to get warm and it is likely to because of the breakdown. Please construct a canopy or baffle board. (local configured).
- When installing the drain pipe, plug all the holes other than the drain pipe mounting hole in the bottom of the outdoor unit with the drain cap so there is no water leakage. (Reverse cycle model only)

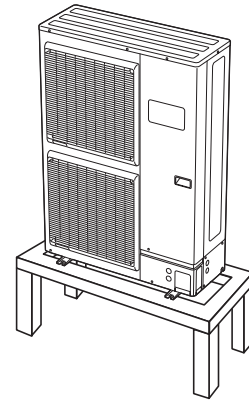
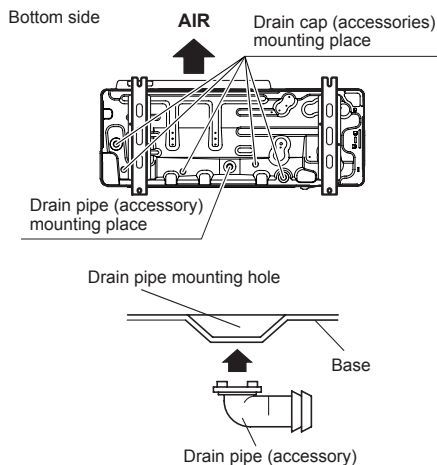

### 4.5. Secure the unit

[Unit: in (mm)]

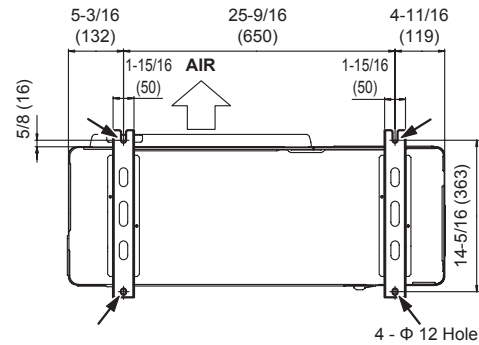

- Install 4 anchor bolts at the locations indicated with arrows in the above figure.
- To reduce vibration, do not install the unit directly on the ground. Install it on a secure base (such as concrete blocks).
- The foundation shall support the legs of the unit and have a width of 2 in (50 mm) or more.
- Depending on the installation conditions, the outdoor unit may spread its vibration during operation, which may cause noise and vibration. Therefore, attach damping materials (such as damping pads) to the outdoor unit during installation.
- Install the foundation, making sure that there is enough space for installing the connection pipes.
- Secure the unit to a solid block using foundation bolts. (Use 4 sets of commercially available M10 bolts, nuts, and washers.)
- The bolts should protrude 13/16 in (20 mm).
- (Refer to the figure below.)
- If overturning prevention is required, purchase the necessary commercially available items.

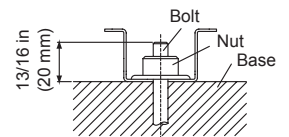

Fix securely with bolts on a solid block. (Use 4 sets of commercially available M10 bolt, nut and washer.)

## 5. PIPE INSTALLATION-1

### 5.1. Opening a knock out hole

#### ⚠ CAUTION

- Be careful not to deform or scratch the panel while opening the knock out holes.
- To protect the piping insulation after opening a knock out hole, remove any burrs from the edge of the hole. It is recommended to apply rust prevention paint to the edge of the hole.
- Pipes can be connected from 4 directions, front, lateral side, rear side and bottom. (Fig. A)
- When connecting at the bottom, remove the service panel and piping cover on the front of the outdoor unit, and open the knock out hole provided at the bottom corner of the piping outlet.
- It can be installed as shown on "Fig. B" cutting out the 2 slits as indicated on "Fig. C". (When cutting slits, use a steel saw.)

Fig. A

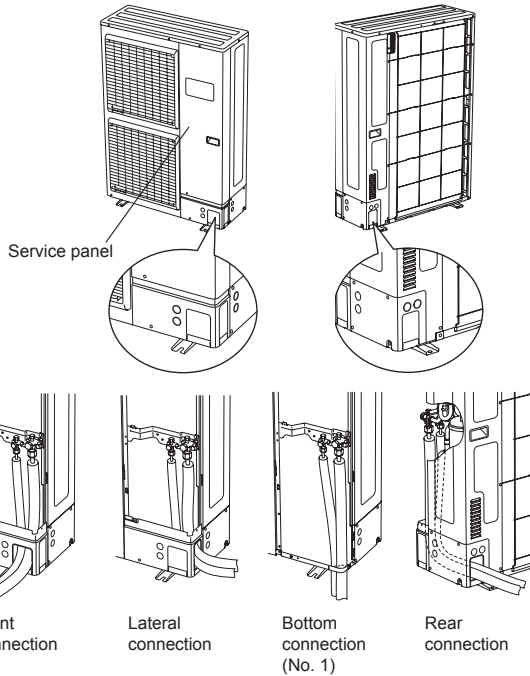

Fig. B

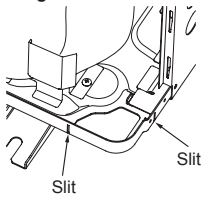
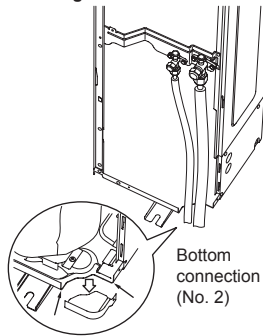

Fig. C



## 5.2. Brazing

### CAUTION

- If air or another type of refrigerant enters the refrigeration cycle, the internal pressure in the refrigeration cycle will become abnormally high and prevent the unit from exerting its full performance.
- Apply nitrogen gas while brazing the pipes. If a pipe is brazed without applying nitrogen gas, an oxidation film will be created. This can degrade performance or damage the parts in the unit (such as the compressor or valves).

Nitrogen gas pressure: 0.02 MPa  
(= pressure felt sufficiently on the back of the hand)

- For brazing material, use phosphor copper that does not require flux. Do not use flux to braze pipes. If the flux is the chlorine type, it will cause the pipes to corrode. Furthermore, if the flux contains fluoride, it will adversely affect the refrigerant pipe system such as by degrading the refrigerant. If fluoride is contained, quality of refrigerant deteriorates and affects the refrigerant piping system.

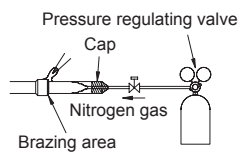

## 5.3. Flare connection (pipe connection)

### CAUTION

- Do not use mineral oil on a flared part. Prevent mineral oil from getting into the system as this would reduce the lifetime of the units.
- While brazing the pipes, be sure to blow dry nitrogen gas through them.
- The maximum lengths of this product are shown in the table. If the units are further apart than this, correct operation cannot be guaranteed.

### 5.3.1. Flaring

Use special pipe cutter and flare tool exclusive for R410A.

- Cut the connection pipe to the necessary length with a pipe cutter.
- Hold the pipe downward so that the cuttings will not enter the pipe and remove any burrs.
- Insert the flare nut (always use the flare nut attached to the indoor and outdoor units respectively) onto the pipe and perform the flare processing with a flare tool. Leakage of refrigerant may result if other flare nuts are used.

- Protect the pipes by pinching them or with tape to prevent dust, dirt, or water from entering the pipes.

Check if [L] is flared uniformly and is not cracked or scratched.

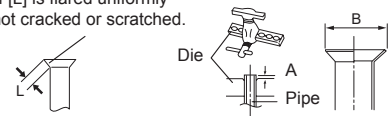

Pipe outside diameter [in (mm)]	Dimension A [in (mm)]	Dimension B [in (mm)]
	Flare tool for R410A, clutch type	
1/4 (6.35)	0 to 0.020 (0 to 0.5)	3/8 (9.1)
3/8 (9.52)		1/2 (13.2)
1/2 (12.70)		5/8 (16.6)
5/8 (15.88)		3/4 (19.7)
3/4 (19.05)		15/16 (24.0)

When using conventional flare tools to flare R410A pipes, the dimension A should be approximately 0.020 in (0.5 mm) more than indicated in the table (for flaring with R410A flare tools) to achieve the specified flaring. Use a thickness gauge to measure the dimension A.

Width across flats



Pipe outside diameter [in (mm)]	Width across flats of Flare nut [in (mm)]
1/4 (6.35)	11/16 (17)
3/8 (9.52)	7/8 (22)
1/2 (12.70)	1 (26)
5/8 (15.88)	1-1/8 (29)
3/4 (19.05)	1-7/16 (36)

### 5.3.2. Bending pipes

#### CAUTION

- To prevent breaking of the pipe, avoid sharp bends. Bend the pipe with a radius of curvature of 3-15/16 in (100 mm) to 5-14/16 in (150 mm).
- If the pipe is bent repeatedly at the same place, it will break.
- If pipes are shaped by hand, be careful not to collapse them.
- Do not bend the pipes at an angle of more than 90°.
- When pipes are repeatedly bent or stretched, the material will harden, making it difficult to bend or stretch them any more.
- Do not bend or stretch the pipes more than three times.

### 5.3.3. Pipe connection

#### CAUTION

- Be sure to install the pipe against the port on the indoor unit and the outdoor unit correctly. If the centering is improper, the flare nut cannot be tightened smoothly. If the flare nut is forced to turn, the threads will be damaged.
- Do not remove the flare nut from the outdoor unit pipe until immediately before connecting the connection pipe.
- After installing the piping, make sure that the connection pipes do not touch the compressor or outer panel. If the pipes touch the compressor or outer panel, they will vibrate and produce noise.

- Detach the caps and plugs from the pipes.
- Center the pipe against the port on the outdoor unit, and then turn the flare nut by hand.
- Tighten the flare nut of the connection pipe at the outdoor unit valve connector.

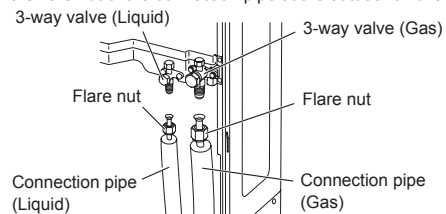

- After tightening the flare nut by hand, use a torque wrench to fully tighten it.

#### CAUTION

Hold the torque wrench at its grip, keeping it in a right angle with the pipe, in order to tighten the flare nut correctly.

- Outer panel may be distorted if fastened only with a wrench. Be sure to fix the elementary part with a spanner and fasten with a wrench (refer to below diagram).
- Do not apply force to the blank cap of the valve or hang a wrench, etc., on the cap. It may cause leakage of refrigerant.

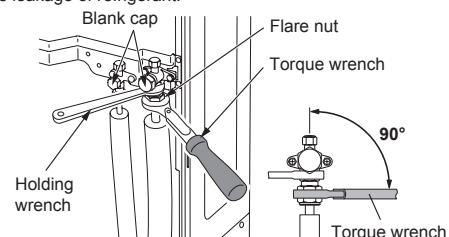

Flare nut [in (mm)]	Tightening torque [ft-lb (N·m)]
1/4 (6.35) dia.	12 to 13 (16 to 18)
3/8 (9.52) dia.	24 to 31 (32 to 42)
1/2 (12.70) dia.	36 to 45 (49 to 61)
5/8 (15.88) dia.	46 to 55 (63 to 75)
3/4 (19.05) dia.	66 to 81 (90 to 110)

### 5.3.4. Handling precautions for the valves

- Mounted part of Blank cap is sealed for protection.
- Fasten blank cap tightly after opening valves.

### Operating the valves

- Use a hexagon wrench [Size: 3/16 in (4 mm)]
- Opening
  - (1) Insert the hexagon wrench into the valve shaft, and turn it counterclockwise.
  - (2) Stop turning when the valve shaft can no longer be turned. (Open position)
- Closing
  - (1) Insert the hexagon wrench into the valve shaft, and turn it clockwise.
  - (2) Stop turning when the valve shaft can no longer be turned. (Closed position)

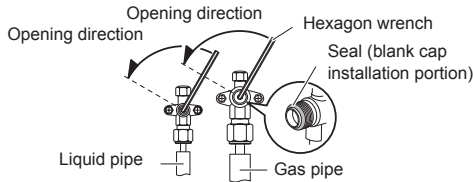

### 5.4. Sealing test

#### ⚠ WARNING

- Before operating the compressor, install the pipes and securely connect them. Otherwise, if the pipes are not installed and if the valves are open when the compressor operates, air could enter the refrigeration cycle. If this happens, the pressure in the refrigeration cycle will become abnormally high and cause damage or injury.
- After the installation, make sure there is no refrigerant leakage. If the refrigerant leaks into the room and becomes exposed to a source of fire such as a fan heater, stove, or burner, it produces a toxic gas.
- Do not subject the pipes to strong shocks during the sealing test. It can rupture the pipes and cause serious injury.

#### ⚠ CAUTION

Do not block the walls and the ceiling until the sealing test and the charging of the refrigerant gas have been completed.

- After connecting the pipes, perform a sealing test.
- Make sure that the 3-way valves are closed before performing a sealing test.
- Pressurize nitrogen gas to 4.15 MPa to perform the sealing test.
- Add nitrogen gas to both the liquid pipes and the gas pipes.
- Check all flare connections and welds. Then, check that the pressure has not decreased.
- Compare the pressures after pressurizing and letting it stand for 24 hours, and check that the pressure has not decreased.
  - \* When the outdoor air temperature changes 41°F (5°C), the test pressure changes 0.05 MPa. If the pressure has dropped, the pipe joints may be leaking.
- If a leak is found, immediately repair it and perform the sealing test again.
- After completing the sealing test, release the nitrogen gas from both valves.
- Release the nitrogen gas slowly.

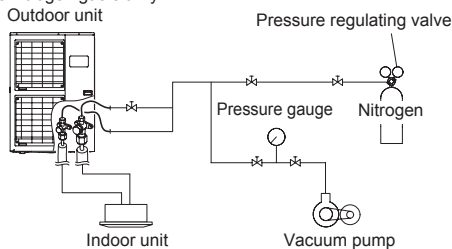

### 5.5. Vacuum process

#### ⚠ CAUTION

- Perform a refrigerant leakage test (air tightness test) to check for leaks using nitrogen gas while all valves in the outdoor unit are closed. (Use the test pressure indicated on the nameplate.)
- Be sure to evacuate the refrigerant system using a vacuum pump.
- The refrigerant pressure may sometimes not rise when a closed valve is opened after the system is evacuated using a vacuum pump. This is caused by the closure of the refrigerant system of the outdoor unit by the electronic expansion valve. This will not affect the operation of the unit.
- If the system is not evacuated sufficiently, its performance will drop.
- Use a clean gauge manifold and charging hose that were designed specifically for use with R410A. Using the same vacuum equipment for different refrigerants may damage the vacuum pump or the unit.
- Do not purge the air with refrigerants, but use a vacuum pump to evacuate the system.

- (1) Check that the valves are closed by removing the blank caps from the gas and liquid pipes.
- (2) Remove the charging port cap, and connect the gauge manifold and the vacuum pump to the charging valve with the service hoses.
- (3) Vacuum the indoor unit and the connecting pipes until the pressure gauge indicates  $-0.1$  MPa ( $-1$  bar).
- (4) When  $-0.1$  MPa ( $-1$  bar) is reached, operate the vacuum pump for at least 60 minutes.
- (5) Disconnect the service hoses and fit the charging port cap to the charging valve to the specified torque.

	Tightening torque [ft-lb (N·m)]
Charging port cap (R410A)	9 to 12 (12.5 to 16)

- (6) Remove the blank caps, and fully open the 3-way valves with a hexagon wrench.
- (7) Tighten the blank caps of the 3-way valve to the specified torque.

Blank cap [in (mm)]	Tightening torque [ft-lb (N·m)]
1/4 (6.35) dia.	15 to 18 (20 to 25)
3/8 (9.52) dia.	15 to 18 (20 to 25)
1/2 (12.70) dia.	21 to 24 (28 to 32)
5/8 (15.88) dia.	22 to 26 (30 to 35)
3/4 (19.05) dia.	26 to 30 (35 to 40)

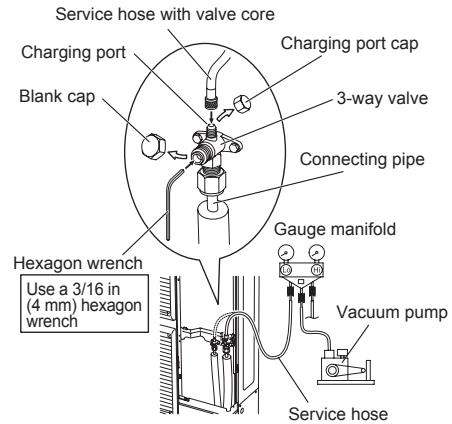

### 5.6. Additional charging

#### ⚠ WARNING

When moving and installing the air conditioner, do not mix gas other than the specified refrigerant R410A inside the refrigerant cycle. If air or other gas enters the refrigerant cycle, the pressure inside the cycle will rise to an abnormally high value and cause breakage, injury, etc.

#### ⚠ CAUTION

- After vacuuming the system, add refrigerant.
- Do not reuse recovered refrigerant.
- When charging the refrigerant R410A, always use an electronic scales for refrigerant charging (to measure the refrigerant by weight). Adding more refrigerant than the specified amount will cause a malfunction.
- When charging the refrigerant, take into account the slight change in the composition of the gas and liquid phases, and always charge from the liquid phase side whose composition is stable. Adding refrigerant through the gas pipe will cause a malfunction.
- Check if the steel cylinder has a siphon installed or not before filling. (There is an indication "with siphon for filling liquid" on the steel cylinder.)

#### Filling method for cylinder with siphon

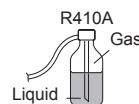

Set the cylinder vertical and fill with the liquid. (Liquid can be filled without turning bottom up with the siphon inside.)

#### Filling method for other cylinders

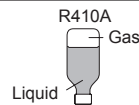

Turn bottom up and fill with liquid. (Be careful to avoid turning over the cylinder.)

- Be sure to use the special tools for R410A for pressure resistance and to avoid mixing of impure substances.
- If the units are further apart than the maximum pipe length, correct operation can not be guaranteed.
- Make sure to back closing valve after refrigerant charging. Otherwise, the compressor may fail.
- Minimize refrigerant release to the air. Excessive release is prohibited under the Freon Collection and Destruction Law.



## 6. ELECTRICAL WIRING

### 6.1. Notes for electrical wiring

#### ⚠ WARNING

- Wiring connections must be performed by a qualified person in accordance with the specifications. The voltage rating for this product is 208-230 V at 60 Hz. It should be operated within the range of 188 to 253 V.
- Before connecting the wires, make sure the power supply is OFF.
- Use a dedicated power supply circuit. Insufficient power capacity in the electrical circuit or improper wiring may cause electric shock or fire.
- Install a breaker at the power supply for each outdoor unit. Improper breaker selection can cause electric shock or fire.
- Install a leakage circuit breaker in accordance with the related laws and regulations. An improperly installed electrical box cover can cause serious accidents such as electric shock or fire through exposure to dust or water.
- A circuit breaker is installed in the permanent wiring. Always use a circuit that can trip all the poles of the wiring and has an isolation distance of at least 1/8 in (3 mm) between the contacts of each pole.
- Use designated cables and power cables. Improper use may cause electric shock or fire by poor connection, insufficient insulation, or over current.
- Do not modify power cable, use extension cable or branch wiring. Improper use may cause electric shock or fire by poor connection, insufficient insulation or over current.
- Connect the connector cable securely to the terminal. Check no mechanical force bears on the cables connected to the terminals. Faulty installation can cause a fire.
- Use ring type terminals and tighten the terminal screws to the specified torques, otherwise, abnormal overheating may be produced and possibly cause serious damage inside the unit.
- Make sure to secure the insulation portion of the connector cable with the cable clamp. Damaged insulation can cause a short circuit.
- Fix cables so that cables do not make contact with the pipes (especially on high pressure side). Do not make power supply cable and connection cable come in contact with valves (Gas).
- Never install a power factor improvement condenser. Instead of improving the power factor, the condenser may overheat.
- Be sure to perform the earthing (grounding) work. Do not connect earthing (grounding) wires to a gas pipe, water pipe, lightning rod or earthing (grounding) wire for a telephone.
  - Connection to a gas pipe may cause a fire or explosion if gas leaks.
  - Connection to a water pipe is not an effective earthing (grounding) method if PVC pipe is used.
  - Connection to the earthing (grounding) wire of a telephone or to a lightning rod may cause a dangerously abnormal rise in the electrical potential if lightning strikes. Improper earthing (grounding) work can cause electric shocks.
- Securely install the electrical box cover on the unit. An improperly installed service panel can cause serious accidents such as electric shock or fire through exposure to dust or water.

#### ⚠ CAUTION

- The primary power supply capacity is for the air conditioner itself, and does not include the concurrent use of other devices.
- Do not start operation until the refrigerant is charged completely. The compressor will fail if it is operated before the refrigerant piping charging is complete.
- Connection cable between indoor unit and outdoor unit is 208-230 V.
- Be sure not to remove thermistor sensor etc. from power wiring and connection wiring. Compressor may fail if operated while removed.
- Start wiring work after closing branch switch and over current breaker.
- Use an earth leakage breaker that is capable of handling high frequencies. Because the outdoor unit is inverter controlled, a high-frequency earth leakage breaker is necessary to prevent a malfunction of the breaker itself.
- When using an earth leakage breaker that has been designed solely for earth (ground) fault protection, be sure to install a fuse-equipped switch or circuit breaker.
- Do not connect the AC power supply to the connection line terminal board. Improper wiring can damage the entire system.
- Do not use crossover power supply wiring for the outdoor unit.
- If the temperature surrounding the breaker is too high, the amperage at which the breaker cuts out may decrease.

#### How to connect wiring to the terminal

##### Caution when wiring cable

When stripping off the coating of a lead wire, always use a special tool such as a wire stripper. If there is no special tool available, carefully strip the coating with a knife etc.

- Use ring terminals with insulating sleeves as shown in the figure below to connect to the terminal block.
- Securely clamp the ring terminals to the wires using an appropriate tool so that the wires do not come loose.

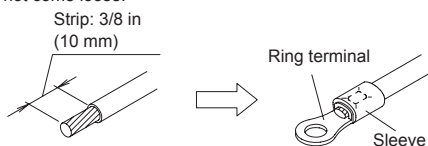

- Use the specified wires, connect them securely, and fasten them so that there is no stress placed on the terminals.
- Use an appropriate screwdriver to tighten the terminal screws. Do not use a screwdriver that is too small, otherwise, the screw heads may be damaged and prevent the screws from being properly tightened.
- Do not tighten the terminal screws too much, otherwise, the screws may break.

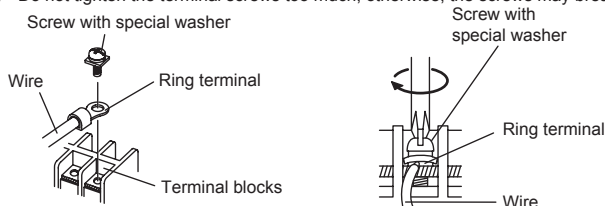

- See the table below for the terminal screw tightening torques.

Tightening torque [lbf-in (N·m)]	
M4 screw	11 to 16 (1.2 to 1.8)
M5 screw	17 to 25 (2.0 to 3.0)

### 6.2. Knock out holes for wiring

#### ⚠ CAUTION

- Be careful not to deform or scratch the panel while opening the knock out holes.
- When cables are routed from the unit, a protection sleeve for the conduits can be inserted at the knock out hole.
- If you do not use a wire conduit, be sure to protect the wires to prevent the edge of the knock out hole from cutting the wires.
- It is recommended to apply anti-rust paint to the edge of the knock out hole.

- Knock out holes are provided for wiring. (Fig. A)
- Knock out holes are provided 2 each in the same size in front, lateral and rear sides. (Fig. B)

Fig. A

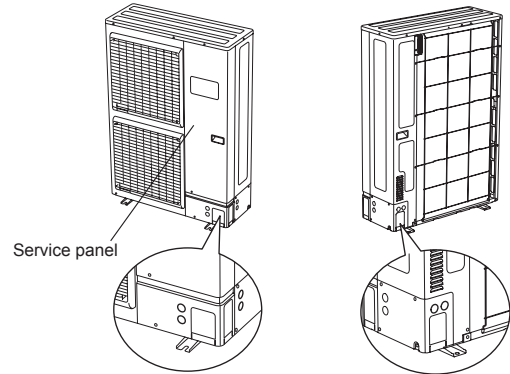
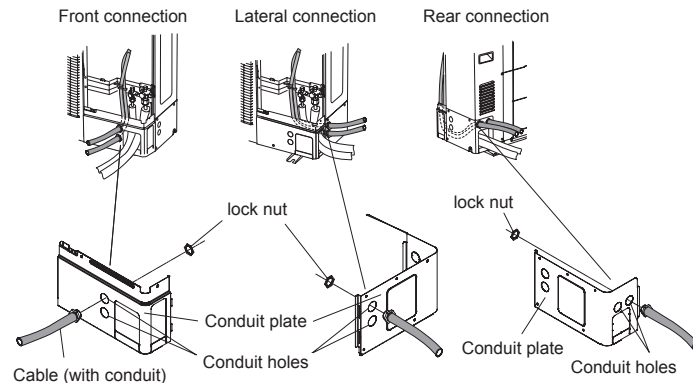

Fig. B

#### Installation method of conduit plate

Please fix the conduit plate as shown in the figure below.



#### NOTES:

- Please ensure that the power cable and interconnecting cables are not installed through the same cable bush hole opening. They must be installed into the two separate hole openings to prevent damage to the cable.
- If conduit holes do not fit, please use a washer (accessory).

### 6.3. Wiring method

#### 6.3.1. Connection diagrams

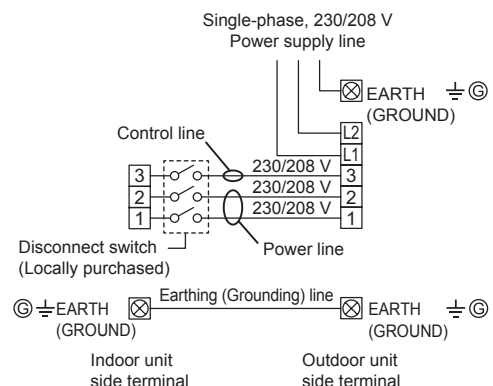

### 6.3.2. Connection cable preparation

Keep the earth (ground) wire longer than the other wires.

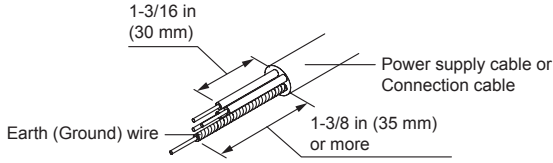

### 6.3.3. Wiring procedure

(1) Remove the service panel cover, insulation sheet and connect the wires to the terminal in accordance with the terminal nameplate. (Fig. A, Fig. B)

Fig. A

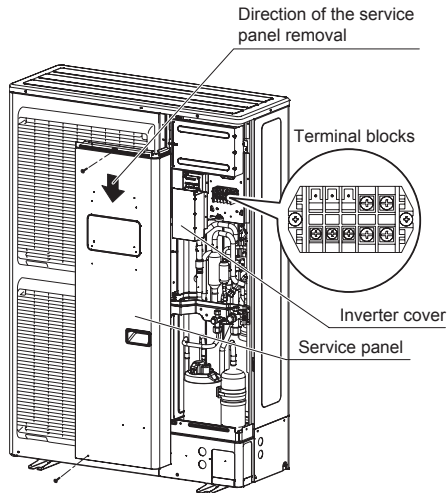

(2) After connecting the wires, use cable clips to secure the wires. (Fig. B)  
 • Connect the wires without applying excessive tension.

Fig. B

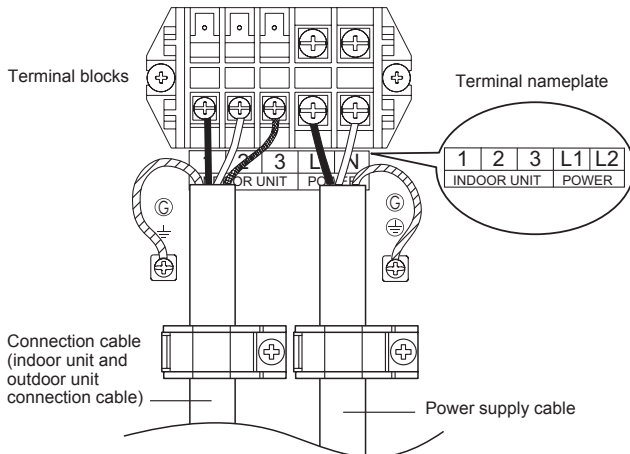

(3) Secure the cables using the cable clips under the terminal blocks, and then secure the cables using the cable clips attached to the base of the valves.

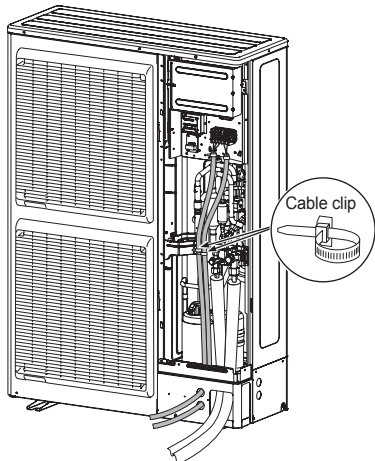

(4) Be sure to install the insulation sheet after the wiring is complete.

## 7. PIPE INSTALLATION-2

### ⚠ WARNING

Install the insulated pipes so that they do not touch the compressor.

### 7.1. Installing insulation

- Use an insulation on the refrigerant pipes to prevent condensation and dripping.
- Determine the thickness of the insulation material by referring to Table A.

**Table A, Selection of insulation**  
 (for using an insulation material with equal heat transmission rate or below 0.040 W/(m·k))

Relative humidity [in (mm)]	Insulation material				
	Minimum thickness [in (mm)]				
	70% or more	75% or more	80% or more	85% or more	
Pipe diameter	1/4 (6.35)	5/16 (8)	13/32 (10)	16/32 (13)	21/32 (17)
	3/8 (9.52)	11/32 (9)	7/16 (11)	18/32 (14)	23/32 (18)
	1/2 (12.70)	13/32 (10)	15/32 (12)	19/32 (15)	3/4 (19)
	5/8 (15.88)	13/32 (10)	15/32 (12)	5/8 (16)	25/32 (20)

If the ambient temperature and relative humidity exceed 89 °F (32 °C), increase the level of heat insulation for the refrigerant pipes.

### 7.2. Filling with putty

### ⚠ WARNING

Fill the piping holes with putty (supplied locally) to avoid any gap (Fig A). If small animals such as insects enter the external unit, a short circuit may be caused near electrical components in the service panel.

If the outdoor unit is installed at a level that is higher than the indoor unit, the water that has condensed in the 3-way valve of the outdoor unit could travel to the indoor unit. Therefore, use putty in the space between the pipe and the insulation to prevent the entry of water.

Fig. A

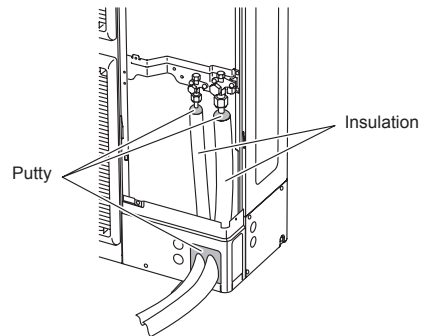

## 8. HOW TO OPERATE DISPLAY UNIT

### 8.1. Display unit position

#### ⚠ WARNING

Never touch electrical components such as the terminal blocks except the button on the display board. It may cause a serious accident such as electric shock.

#### ⚠ CAUTION

- Once refrigerant charging is completed, be sure to open the valve prior to performing the field settings. Otherwise, the compressor may fail.
- Discharge any static electricity from your body before touching the push buttons. Never touch any terminal or pattern of any parts on the control board.
- The positions of the buttons on the outdoor unit control board are shown in the figure below.
- Various settings can be adjusted by changing Push buttons on the board of the outdoor unit.

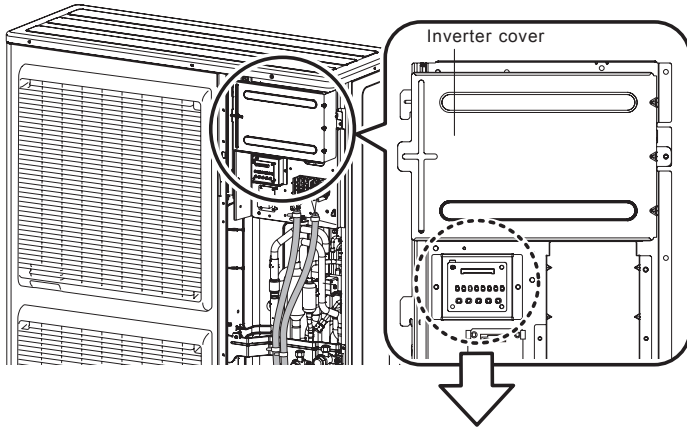

- The printed characters for the LED display are shown below.

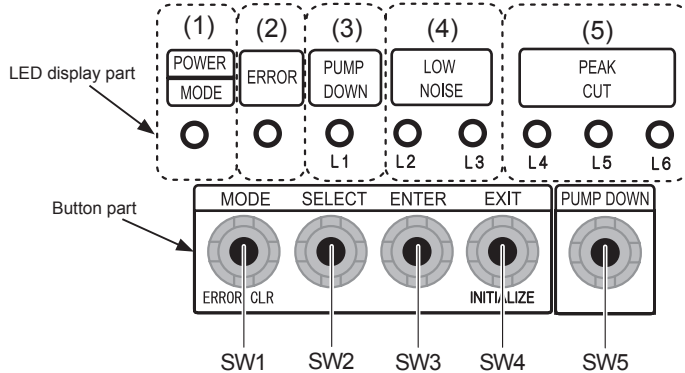

### 8.2. Description of display and button

Display lamp		Function or operation method
(1) POWER / MODE	Green	Lights on while power on. Field setting in outdoor unit or error code is displayed with blink.
(2) ERROR	Red	Blinks during abnormal air conditioner operation.
(3) PUMP DOWN (L1)	Orange	Lights on during pump down operation.
(4) LOW NOISE MODE (L2, L3)	Orange	Lights on during "Low noise" function when field setting is activated. (Lighting pattern of L2 and L3 indicates low noise level) *Refer to "10.1.2. Low noise mode (CN10)".
(5) PEAK CUT (L4, L5, L6)	Orange	Lights on during "Peak cut" function when local setting is activated. (Lighting pattern of L4, L5 and L6 indicates peak cut level) *Refer to "10.1.3. Peak cut mode (CN11)".

Button		Function or operation method
SW1	MODE	To switch between "Field setting" and "Error code display".
SW2	SELECT	To switch between the individual "Field settings" and the "Error code displays".
SW3	ENTER	To fix the individual "Field settings" and the "Error code displays".
SW4	EXIT	To return to "Operation status displays"
SW5	PUMP DOWN	To start the pump down operation.

## 9. FIELD SETTING

#### ⚠ CAUTION

Discharge the static electricity from your body before setting up the switches. Never touch the terminals or the patterns on the parts that are mounted on the board.

### Wall mounted model cannot use this function.

### 9.1. Field setting buttons

- Remove the front panel of the outdoor unit access the print circuit board of the display unit. Print circuit board buttons for various settings and LED displays are shown in the left figure.

### 9.2. Function settings

- Various functions can be set. Follow the setting method described in 9.2.1. to set as per the requirement. Perform these settings after the indoor unit stops.

Table. Settings List

No	Setting Item		LED display							Factory setting	Content	
			POWER/MODE	ERROR	PUMP DOWN (L1)	LOW NOISE (L2) (L3)		PEAK CUT (L4) (L5) (L6)				
1	Low noise mode setting	Level 1	Blink (9 times)	○	○	○	●	○	○	●	○	The noise level when operating in the low noise mode can be set. The operation selection can be done by external input terminal (CN10). Cooling/heating performance decreases by lowering operation noise level.
		Level 2	Blink (9 times)	○	○	○	●	○	●	○		
2	Peak cut mode setting	Level 1	Blink (9 times)	○	○	●	○	○	○	●	○	The capacity limit can be selected when operating with the "Peak Cut mode". The operation selection can be done by external input terminal (CN11). The lower the level, the more the effect of energy saving, but the cooling/heating performance decreases.
		Level 2	Blink (9 times)	○	○	●	○	○	●	○		
		Level 3	Blink (9 times)	○	○	●	○	○	●	●		
		Level 4	Blink (9 times)	○	○	●	○	●	○	○	○	

Sign "○": Lights off, "●": Lights on

### 9.2.1. Setting for low noise mode

- Switch to "Field setting mode" by pressing "MODE" button (SW1) for 3 seconds or more.
- Confirm (POWER / MODE) blinks 9 times, and press "ENTER" button (SW3).

POWER/ MODE	ERROR	PUMP DOWN	LOW NOISE			PEAK CUT		
		(L1)	(L2)	(L3)	(L4)	(L5)	(L6)	
Blink (9 times)	○	○	○	○	○	○	○	

Sign "○": Lights off, "●": Lights on, ( ) : Number of blinking

- Press "SELECT" button (SW2), and adjust LED display as shown below. (Current setting is displayed)

LOW NOISE MODE	LOW NOISE	
	(L2)	(L3)
LOW NOISE MODE	○	Blink

Sign "○": Lights off

- Press "ENTER" button (SW3).

LOW NOISE MODE	LOW NOISE	
	(L2)	(L3)
LOW NOISE MODE	○	●

Sign "○": Lights off, "●": Lights on

- Press "SELECT" button (SW2), and adjust LED lamp as shown in below figure.

	PEAK CUT		
	(L4)	(L5)	(L6)
Level 1	○	○	Blink
Level 2	○	Blink	○

Sign "○": Lights off

The noise of Level 2 is lower than the one of Level 1.

- Press "ENTER" button (SW3) and fix it.

	PEAK CUT		
	(L4)	(L5)	(L6)
Level 1	○	○	●
Level 2	○	●	○

Sign "○": Lights off, "●": Lights on

- Return to "Operating status display (Normal operation)" by pressing "EXIT" button (SW4).

- In case of missing how many times "SELECT" and "ENTER" button are pressed, restart from the beginning of operation procedure after returning to "Operation status display (normal operation)" by pressing the "EXIT" button once.

### 9.2.2. Setting for peak cut mode

- Switch to "Field setting mode" by pressing "MODE" button (SW1) for 3 seconds or more.
- Confirm (POWER / MODE) blinks 9 times, and press "ENTER" button (SW3).

POWER/ MODE	ERROR	PUMP DOWN	LOW NOISE			PEAK CUT		
		(L1)	(L2)	(L3)	(L4)	(L5)	(L6)	
Blink (9 times)	○	○	○	○	○	○	○	

Sign "○": Lights off, "●": Lights on, ( ) : Number of blinking

- Press "SELECT" button (SW2), and adjust LED lamp as shown below. (Current setting is displayed)

PEAK CUT MODE	LOW NOISE	
	(L2)	(L3)
PEAK CUT MODE	Blink	○

Sign "○": Lights off

- Press "ENTER" button (SW3).

PEAK CUT MODE	LOW NOISE	
	(L2)	(L3)
PEAK CUT MODE	●	○

Sign "○": Lights off, "●": Lights on

- Press "SELECT" button (SW2), and adjust LED lamp as shown in below figure.

		PEAK CUT		
		(L4)	(L5)	(L6)
Level 1	0% of rated input ratio	○	○	Blink
Level 2	50% of rated input ratio	○	Blink	○
Level 3	75% of rated input ratio	○	Blink	Blink
Level 4	100% of rated input ratio	Blink	○	○

Sign "○": Lights off

- Press "ENTER" button (SW3) and fix it.

		PEAK CUT		
		(L4)	(L5)	(L6)
Level 1	0% of rated input ratio	○	○	●
Level 2	50% of rated input ratio	○	●	○
Level 3	75% of rated input ratio	○	●	●
Level 4	100% of rated input ratio	●	○	○

Sign "○": Lights off, "●": Lights on

- Return to "Operating status display (Normal operation)" by pressing "EXIT" button (SW4).

- When pressed number is lost during operation, restart from the beginning of operation procedure after returning to "Operation status display (normal operation)" by pressing the "EXIT" button once.



## 10. EXTERNAL INPUT AND OUTPUT

Wall mounted model cannot use this function.

### 10.1. External input

#### 10.1.1. Wiring of connector

ON/OFF of the "Low noise mode", and "Peak cut mode" functions can be enabled with an external field device.

When installing connection cable, specified part (optional parts) must be used.

Refer to section 9.2, Table. Settings List, for the required function. The function must be set for the external input to work.

Input	Connector No.	Optional parts
Low noise mode	CN10	External connect kit
Peak cut mode	CN11	External connect kit

\* Make the distance from the PC board to the connected unit within 10m (33ft).

• Contact capacity : 24VDC or more, 10mA or more.

Circuit diagram example

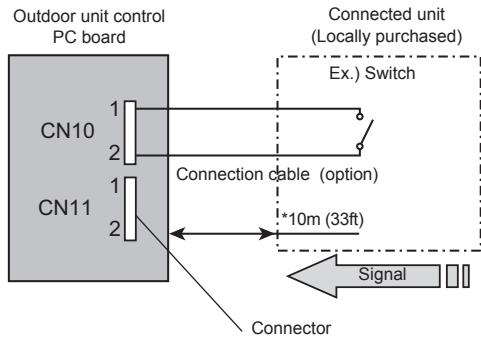

#### 10.1.2. Low noise mode (CN10)

- This feature reduces the operating sound of the outdoor unit from the normal sound. The air conditioner is set to the "Low noise mode" when closing the contact input of a commercial timer or ON/OFF switch to a connector on the outdoor control PC board.
- \* Performance may drop depending on the outside air temperature condition, etc.

\* Set the "Low noise mode" level, refer to "9.2. Function settings".

Input Signal ...ON : Low noise mode  
...OFF : Normal operation

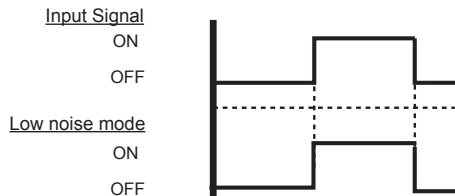

#### 10.1.3. Peak cut mode (CN11)

- Operation that suppressed the current value can be performed by means of the connected unit. The air conditioner is set to the Peak cut mode by applying the contact input of a commercial ON/OFF switch to a connector on the outdoor control PC board.

\* Set the "Peak cut mode" level, refer to "9.2. Function settings".

Input Signal ...ON : Peak cut mode  
...OFF : Normal operation

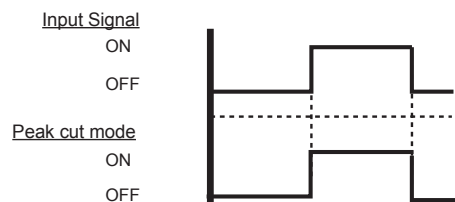

## 10.2. External output

### 10.2.1. Wiring of connector

When installing connection cable, specified part (optional parts) must be used.

Output	Connector No.	Optional parts
Error status	CN12	External connect kit
Compressor status	CN13	External connect kit

\* Make the distance from the PC board to the connected unit within 10m (33ft).

- 1) Power supply
  - Voltage (Chart sign=Vcc) : DC 24V or less
- 2) Load
  - Load : DC 500mA or less is recommended

Circuit diagram example

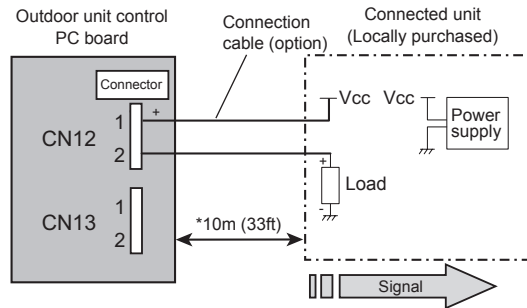

### 10.2.2. Error status output (CN12)

An air conditioner error status signal is produced when a malfunction occurs.

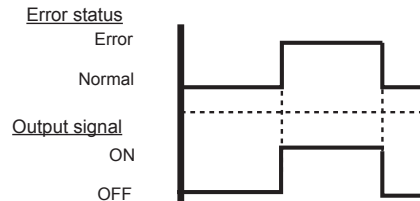

### 10.2.3. Compressor status output (CN13)

Compressor operation status signal is produced when the compressor is running.

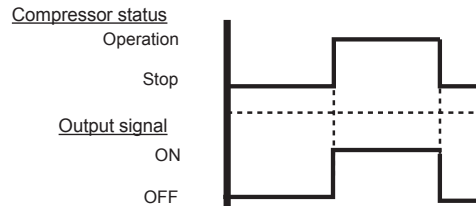

## 10.3. Connection method

### CAUTION

Do not fix with the fan motor cable.  
Do not route the connection cable overlapping with the power supply cable.

Remove the Inverter cover before work.

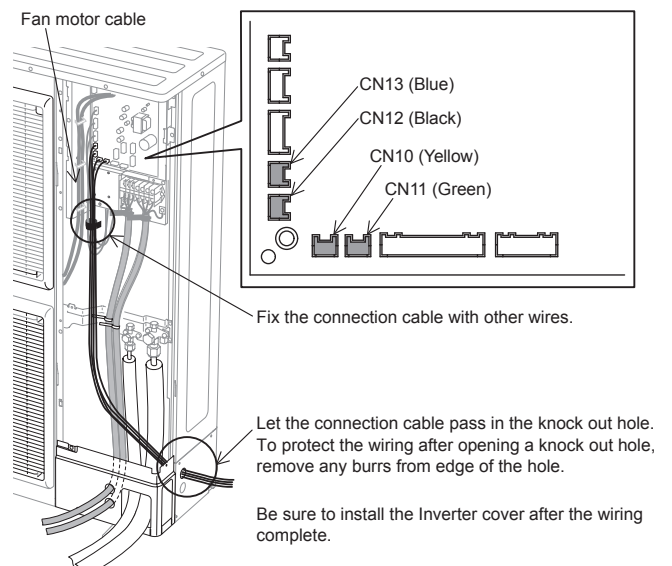

## 11. TEST RUN

### 11.1. Pre-test run check items

Before the test operation, refer to the figure and check the following items.

<input type="checkbox"/>	Is the outdoor unit securely installed?
<input type="checkbox"/>	Have you performed gas leakage inspection? (Connection joints of various pipes (flange connection, brazing))
<input type="checkbox"/>	Is the heat insulation done completely? (Gas pipe, liquid pipe, drain hose extension on indoor unit side, etc.)
<input type="checkbox"/>	Is the water discharging from drain without any problems?
<input type="checkbox"/>	Are the cables connected correctly?
<input type="checkbox"/>	Are the cables as per specifications?
<input type="checkbox"/>	Is the earth wire connected accurately?
<input type="checkbox"/>	Are there any obstacles blocking the suction gate, and outlet of the indoor/outdoor units?
<input type="checkbox"/>	Have you filled the specified amount of refrigerant?
<input type="checkbox"/>	Are the stop valves of gas pipe and liquid pipe fully open?
<input type="checkbox"/>	Has the power been supplied to crankcase heater for more than 6 hours?

After checking that the above items are all in order, refer to "11.2. Test operation method" to test operation the unit. If there are problems, adjust immediately and recheck.

### 11.2. Test operation method

Be sure to configure test run settings only when the outdoor unit has stopped operating.

- Depending on the communication status between the indoor and outdoor units, it may take several minutes for the system to start operating after settings for the test run are complete.
- After the test run settings are complete, the outdoor units and the connected indoor units will start operating. Room temperature control will not activate during test operation (continuous operation).
- If a knocking sound can be heard in the liquid compression of the compressor, stop the unit immediately and then energize the crank case heater for a sufficient length of time before restarting the operation.

Test operation setting method (It can be performed in the following two ways)

- Set with test operation setting (refer to installation manual of indoor unit for further details) available in the remote controller.
- "Cooling Operation" and "Heating Operation" can be set, using "SELECT" button and "ENTER" button available on the board of display unit.  
(\*Make sure to perform the first test operation with cooling operation.)  
Set as per the procedure given below.

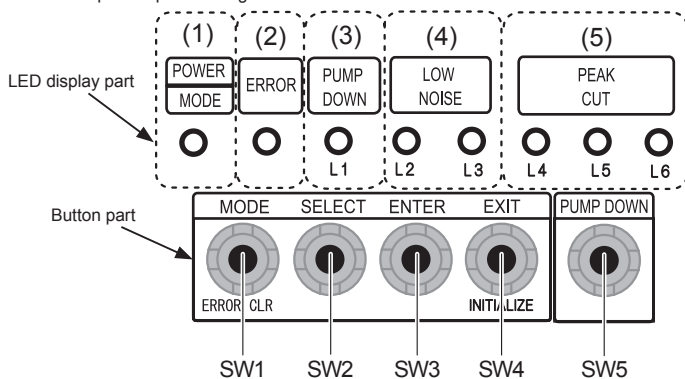

### 11.2.1. Setting method on outdoor unit board

- Turn on the power of the outdoor unit and enter standby mode.  
"POWER/MODE" Lamp lights up.

POWER/ MODE	ERROR	PUMP DOWN	LOW NOISE		PEAK CUT		
		(L1)	(L2)	(L3)	(L4)	(L5)	(L6)
●	○	○	○	○	○	○	○

Sign "○": Lights off, "●": Lights on

- Press the "ENTER" button for more than 3 seconds.

POWER/ MODE	ERROR	PUMP DOWN	LOW NOISE		PEAK CUT		
		(L1)	(L2)	(L3)	(L4)	(L5)	(L6)
Blink	○	○	○	Blink	○	○	○

Sign "○": Lights off, "●": Lights on

- Press the "SELECT" button, LED of the test run mode switched between "COOL" and "HEAT".

Cooling test mode

POWER/ MODE	ERROR	PUMP DOWN	LOW NOISE		PEAK CUT		
		(L1)	(L2)	(L3)	(L4)	(L5)	(L6)
Blink	○	○	○	Blink	○	○	○

Sign "○": Lights off, "●": Lights on

Heating test mode

POWER/ MODE	ERROR	PUMP DOWN	LOW NOISE		PEAK CUT		
		(L1)	(L2)	(L3)	(L4)	(L5)	(L6)
Blink	○	○	Blink	○	○	○	○

Sign "○": Lights off, "●": Lights on

- After confirming the operation mode, Press "ENTER" button.

The display changes as follows, and air conditioner starts operation.

Cooling test mode

POWER/ MODE	ERROR	PUMP DOWN	LOW NOISE		PEAK CUT		
		(L1)	(L2)	(L3)	(L4)	(L5)	(L6)
Blink	○	○	○	●	○	○	○

Sign "○": Lights off, "●": Lights on

Heating test mode

POWER/ MODE	ERROR	PUMP DOWN	LOW NOISE		PEAK CUT		
		(L1)	(L2)	(L3)	(L4)	(L5)	(L6)
Blink	○	○	●	○	○	○	○

Sign "○": Lights off, "●": Lights on

- Press "ENTER" button.

Air conditioner stopped operation.

POWER/ MODE	ERROR	PUMP DOWN	LOW NOISE		PEAK CUT		
		(L1)	(L2)	(L3)	(L4)	(L5)	(L6)
●	○	○	○	○	○	○	○

Sign "○": Lights off, "●": Lights on

### 11.3. Check list

Check items during test operation.

<input type="checkbox"/>	Is the outdoor unit making any abnormal noise or vibrating significantly?
<input type="checkbox"/>	Is the cold air or hot air blowing from indoor unit according to the operation mode?
<input type="checkbox"/>	Check that the "ERROR" LED blinks. If, it has displayed, check the error content as per 12.2. described later.
<input type="checkbox"/>	Operate the unit according to the operating manual provided with the indoor unit, and check that it is operating normally.

## 12. ERROR CODE

You can determine the operating status by the lighting up and blinking of the LED lamp.

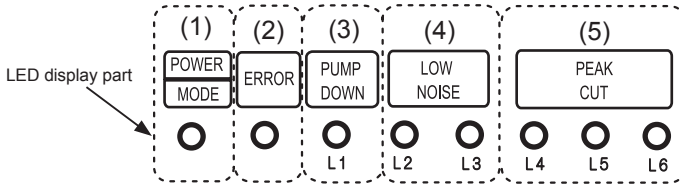

## 12.1. Error display mode

Display when an error occurs.

POWER/ MODE	ERROR	PUMP DOWN	LOW NOISE			PEAK CUT		
		(L1)	(L2)	(L3)	(L4)	(L5)	(L6)	
●	Blink (Hi speed)	○	○	○	○	○	○	○

Sign "○": Lights off, "●": Lights on

- (1) Check that the "ERROR" LED blinks, then press the "ENTER" button once.
- (2) For details, refer to the following table.

## 12.2. Error code check table

LED display								DESCRIPTION	REMARK
POWER/ MODE	ERROR	PUMP DOWN (L1)	LOW NOISE (L2) (L3)		PEAK CUT (L4) (L5) (L6)				
◆(2)	●	◆(1)	◆(1)	○	○	●	●	Serial communication error	Serial forward transmission error immediately after operation
◆(2)	●	◆(1)	◆(1)	○	●	○	○		Serial forward transmission error during operation
◆(2)	●	◆(2)	◆(2)	○	○	○	●	Indoor unit capacity error	Indoor unit capacity error
◆(2)	●	◆(5)	◆(15)	○	○	○	●	Indoor unit error	Indoor unit error
◆(2)	●	◆(6)	◆(2)	○	○	○	●	Outdoor unit main PCB error	Outdoor unit PCB model information error
◆(2)	●	◆(6)	◆(3)	○	○	○	●	Inverter PCB error	Inverter error
◆(2)	●	◆(6)	◆(5)	○	○	●	●	IPM error	Trip terminal L error
◆(2)	●	◆(7)	◆(1)	○	○	○	●	Discharge temp. sensor error	Discharge temp. sensor 1 error
◆(2)	●	◆(7)	◆(2)	○	○	○	●	Compressor temp. sensor error	Compressor temp. sensor 1 error
◆(2)	●	◆(7)	◆(3)	○	○	●	○	Outdoor unit Heat Ex. sensor error	Heat Ex. middle temp. sensor error
◆(2)	●	◆(7)	◆(3)	○	○	●	●		Outdoor unit Heat Ex. liquid temp. sensor error
◆(2)	●	◆(7)	◆(4)	○	○	○	●	Outdoor temp. sensor error	Outdoor temp. sensor error
◆(2)	●	◆(7)	◆(7)	○	○	○	●	Heat sink temp. sensor error	Heat sink temp. sensor error
◆(2)	●	◆(8)	◆(4)	○	○	○	●	Current sensor error	Current sensor 1 error (stoppage permanently)
◆(2)	●	◆(8)	◆(6)	○	●	○	○	Pressure sensor error	High pressure switch 1 error
◆(2)	●	◆(8)	◆(6)	○	●	●	○		Pressure sensor error
◆(2)	●	◆(9)	◆(4)	○	○	○	●	Trip detection	Trip detection
◆(2)	●	◆(9)	◆(5)	○	○	○	●	Compressor motor control error	Rotor position detection error (stoppage permanently)
◆(2)	●	◆(9)	◆(7)	○	○	●	●	Outdoor unit fan motor 1 error	Duty error
◆(2)	●	◆(9)	◆(8)	○	○	●	●	Outdoor unit fan motor 2 error	Duty error
◆(2)	●	◆(9)	◆(9)	○	○	○	●	4-way valve error	4-way valve error
◆(2)	●	◆(10)	◆(1)	○	○	○	●	Discharge temp. 1 error	Discharge temp. 1 error
◆(2)	●	◆(10)	◆(3)	○	○	○	●	Compressor temp. error	Compressor 1 temp. error
◆(2)	●	◆(10)	◆(5)	○	○	○	●	Pressure error 2	Low pressure error

Display mode ●: Lights on  
○: Lights off  
◆: Blink (0.5s Lights on / 0.5s Lights off)  
( ): Number of flashing

## 13. PUMP DOWN

### ⚠ WARNING

- Never touch electrical components such as the terminal blocks except the button on the display board. It may cause a serious accident such as electric shock.
- During the pump-down operation, make sure that the compressor is turned off before you remove the refrigerant piping.  
Do not remove the connection pipe while the compressor is in operation with valves open. This may cause abnormal pressure in the refrigeration cycle that leads to breakage and even injury.

### ⚠ CAUTION

- Perform the pump down operation before disconnecting any refrigerant pipe or electric cable.
- Collect refrigerant from the service port or the 3-way valve if pump down cannot be performed.
- In case of a group control system installation, do not turn the power off pump down is completed in all outdoor units.  
(Group control system installation described in "SPECIAL INSTALLATION METHODS" in the installation manual of the indoor unit.)
- Please check the refrigerant circuit for any leaks before starting the pump down operation.  
Do not proceed with the pump down operation if there is no refrigerant left in the circuit due to bent or broken piping.

- Operate "PUMP DOWN" button on the display board in the manner described below.

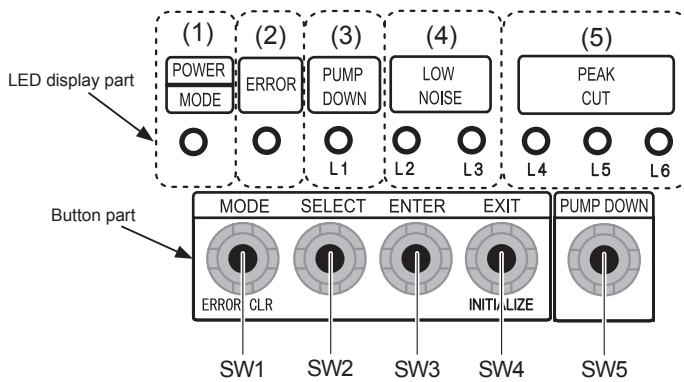

### 13.1. Preparation for pump down

- Confirm that the power is off, and then open the service panel.

### 13.2. Pump down procedure

- Check the 3-way valves (both the liquid side and gas side) are opened.
- Turn the power on.

POWER/ MODE	ERROR	PUMP DOWN	LOW NOISE			PEAK CUT		
		(L1)	(L2)	(L3)	(L4)	(L5)	(L6)	
●	○	○	○	○	○	○	○	○

Sign "○": Lights off, "●": Lights on

- Press "PUMP DOWN" button for 3 seconds or more after 3 minutes after power on.

POWER/ MODE	ERROR	PUMP DOWN	LOW NOISE			PEAK CUT		
		(L1)	(L2)	(L3)	(L4)	(L5)	(L6)	
●	○	●	○	○	●	●	●	

Sign "○": Lights off, "●": Lights on

LED display lights on as shown in the above figure, and the fans and the compressor start operating.

- If the "PUMP DOWN" button is pressed while the compressor is operating, the compressor will stop, then start again in about 3 minutes.

- LED display will change as shown below about 3 minutes after the compressor starts. Fully close the 3-way valve on the liquid pipe side at this stage.

POWER/ MODE	ERROR	PUMP DOWN	LOW NOISE			PEAK CUT		
		(L1)	(L2)	(L3)	(L4)	(L5)	(L6)	
●	○	●	○	○	○	●	●	

Sign "○": Lights off, "●": Lights on

- If the valve on the liquid pipe side is not closed, the pump down cannot be performed.

- When LED display changes as shown in the below figure, close the 3-way valve on the gas pipe side tightly.

POWER/ MODE	ERROR	PUMP DOWN	LOW NOISE			PEAK CUT		
		(L1)	(L2)	(L3)	(L4)	(L5)	(L6)	
●	○	●	○	○	○	○	●	

Sign "○": Lights off, "●": Lights on

- If the valve on the gas pipe side is not closed, refrigerant may flow into the piping after the compressor stops.

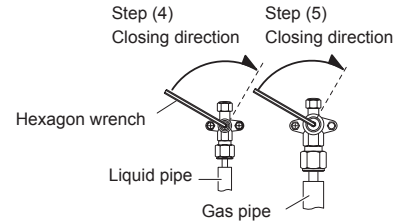

- LED display changes after 1 minute as shown in the figure below.

POWER/ MODE	ERROR	PUMP DOWN	LOW NOISE			PEAK CUT		
		(L1)	(L2)	(L3)	(L4)	(L5)	(L6)	
●	○	●	○	○	○	○	○	

Sign "○": Lights off, "●": Lights on

Fans and compressor stop automatically.

- If the pump down is successfully completed (the above LED display is shown), the outdoor unit remains stopped until the power is turned off.

- Turn the power off.

POWER/ MODE	ERROR	PUMP DOWN	LOW NOISE			PEAK CUT		
		(L1)	(L2)	(L3)	(L4)	(L5)	(L6)	
○	○	○	○	○	○	○	○	

Sign "○": Lights off

PUMP DOWN is completed.

#### NOTES:

- To stop pump down, press the "PUMP DOWN" button again.
- To start the pump down again after the compressor is automatically stopped due to an error, turn the power off and open the 3-way valves. Wait 3 minutes, turn the power on and start the pump down again.
- When starting the operation after completion of the pump down, turn the power off, and then open the 3-way valves. Wait 3 minutes, turn the power on and perform a test run in the "COOL" operation mode.
- If an error occurs, recover the refrigerant from service port.