

**Inverter Driven Heat Pump**

**12,000 BTU Compact Cassette Type**

Job Name \_\_\_\_\_  
 Location \_\_\_\_\_  
 Engineer \_\_\_\_\_  
 Submitted To \_\_\_\_\_  
 Submitted By \_\_\_\_\_  
 Reference \_\_\_\_\_

Date \_\_\_\_\_  
 Approval \_\_\_\_\_  
 Construction \_\_\_\_\_  
 Unit No \_\_\_\_\_  
 Drawing No \_\_\_\_\_

**PRODUCT FEATURES**

- Automatic airflow adjustment
- Auto/Cool/Dry/Fan/Heat/modes
- 24 Hr. timer
- Powerful mode
- Fresh Air Knockout
- Fresh Air Kit
- Auto changeover
- Cold prevention
- Compact size - Grid fit



**MODEL NUMBERS**

Indoor Unit	ACUH12LUAS1
Nominal Capacity	12,000

**LINESET REQUIREMENTS**

Connection Method	Flare	
Liquid	in (mm)	Ø1/4 (Ø 6.35)
Gas		Ø3/8 (Ø9.52)
Drain hose	Material	PVC
	in	Ø 1 (I.D.), Ø 1-1/4 (O.D.)
	mm	Ø 25 (I.D.), Ø 32 (O.D.)

**INDOOR DIMENSIONS & WEIGHT**

Net (H x W x D)	in	9-5/8 x 22-7/16 x 22-7/16
	mm	245 x 570 x 570
Gross (H x W x D)	in	10-7/16 x 28-3/4 x 24-5/8
	mm	265 x 730 x 625
Net Weight	lb (kg)	33 (15)
Gross Weight		40 (18)

**ELECTRICAL SPECIFICATIONS**

Voltage/Frequency/Phase	208/230 V ~ 60 Hz	
Voltage Range	187-264 V	
Running Current	A	0.19
Input Power	W	23

**SOUND PRESSURE**

Indoor Unit	Cooling	High	dB (A)	37
		Medium		33
		Low		31
		Quiet		28
	Heating	High	dB (A)	37
		Medium		33
		Low		31
		Quiet		28

**FAN DATA**

Airflow Rate	Cooling	High	CFM (m3/h)	359 (610)
		Medium		312 (530)
		Low		277 (470)
		Quiet		241 (410)
	Heating	High	CFM (m3/h)	359 (610)
		Medium		312 (530)
		Low		277 (470)
		Quiet		241 (410)

**Warranty Information**



7 Year Compressor, 5 Year Parts out-of-the-box Warranty



10 Year Compressor, 10 Year Parts Warranty when registered within 60 days of installation in a residence



12 Year Compressor, 12 Year Parts Warranty when registered within 60 days of installation in a residence, and installed by a Fujitsu Elite contractor

**ENCLOSURE**

Enclosure	Material	Polystyrene
	Color	White

**ACCESSORIES**

UTY-XWZXZG	External Connect Kit
UTY-TFSXZ2	Wireless LAN Interface
UTY-RNRUZ Series	Wired Remote Controller
UTY-RHRY	Simple Remote Controller
UTY-RSRY	Simple Remote Controller
UYT-LNTU	Wireless Remote Controller
UTZ-VXAA	Fresh Air Intake
UTR-YDZB	Air Outlet Shutter Plate
UTZ-VMSX	MODBUS Converter
FJ-AC-BAC-1L	BACnet Gateway
UTG-CCGFGA	Cassette Grille



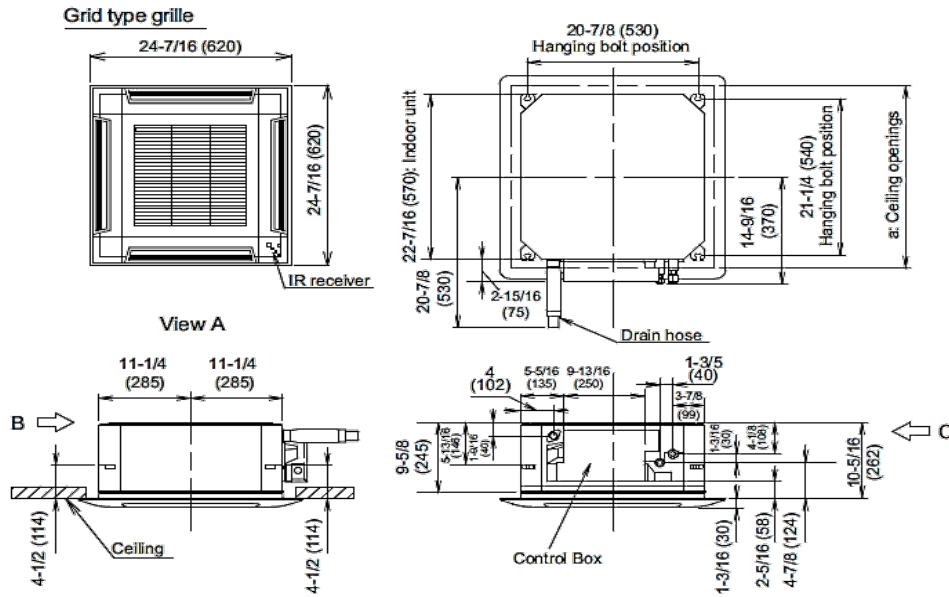

■ Installation space requirement

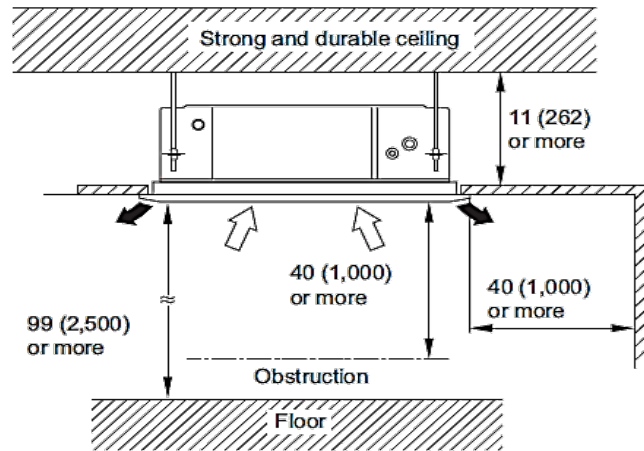

The Fujitsu logo is a worldwide trademark of Fujitsu General Limited. The Halcyon logo and name is a worldwide trademark of Fujitsu General America, Inc. Fujitsu's products are subject to continuous improvements. Fujitsu reserves the right to modify product design, specifications and information in this brochure without notice and without incurring any obligations.

Note: Specifications are based on the following conditions:  
 Cooling: Indoor temperature of 80°F (26.7°C) DB/67°F (19.4°C) WB, and outdoor temperature of 95°F (35°C) DB/75°F (23.9°C) WB. Heating: Indoor temperature of 70°F (21.1°C) DB/60°F (15.6°C) WB, and outdoor temperature of 47°F (8.3°C) DB/43°F (6.1°C) WB. Pipe length: 25ft. (7.5m), Height difference: 0ft. (0m) (Outdoor unit - indoor unit).