

Inverter Driven Heat Pump

12,000 BTU Single Zone Compact Cassette

Job Name _____
 Location _____
 Engineer _____
 Submitted To _____
 Submitted By _____
 Reference _____

Date _____
 Approval _____
 Construction _____
 Unit No _____
 Drawing No _____

PRODUCT FEATURES

- 24 hr. Timer/Weekly Timer
- Auto louver: Up/Down
- Auto Mode
- Auto Changeover
- Daisy Chain Compatible
- Built-in Condensate Pump
- Auto Restart
- Economy Mode
- Auto Fan Mode



| MODEL NUMBERS | |
|---------------|-------------|
| Indoor Unit | ACUH12LUAS1 |
| Outdoor Unit | AOUH12LUAS1 |
| System | 12LUAS1C |

| EFFICIENCIES | | |
|--------------|--------|------|
| SEER | 22.1 | |
| EER | 12.8 | |
| HSPF | 12.2 | |
| COP | kW/kW | 3.25 |
| | Btu/hW | 11.1 |

| OUTDOOR TEMPERATURE OPERATION RANGE | |
|-------------------------------------|------------------------------|
| Cooling | °F(°C) 14 to 115 (-10 to 46) |
| Heating | -5 to 75 (-21 to 24) |

| CAPACITIES | | | |
|------------|-----------|--------|----------------|
| Cooling | Rated | BTU/hW | 12,000 |
| | Min.—Max. | | 3,100 - 13,600 |
| Heating | Rated | BTU/hW | 16,000 |
| | Min.—Max. | | 3,100 - 19,400 |

| LINESET REQUIREMENTS | | |
|----------------------|---------|--------------|
| Connection Method | | Flare |
| Liquid | in (mm) | Ø1/4 (Ø6.35) |
| Gas | | Ø3/8 (Ø9.52) |
| Pre-Charge Length | ft (m) | 49 (15) |
| Minimum Length | | 16 (5) |
| Maximum Length | | 66 (20) |
| Max. Height Diff. | | 49 (15) |

| INDOOR DIMENSIONS & WEIGHT | | |
|----------------------------|---------|-----------------------------|
| Net (H x W x D) | in | 9-5/8 x 22-7/16 x 22-7/16 |
| | mm | (245x570x570) |
| Gross (H x W x D) | in | 10-7/16 x 28-3/4 x 24-19/32 |
| | mm | (265x730x625) |
| Net Weight | lb (kg) | 33 (15) |
| Gross Weight | | 40 (18) |

| OUTDOOR DIMENSIONS & WEIGHT | | |
|-----------------------------|---------|----------------------------|
| Net (H x W x D) | in | 24-7/8 x 31-7/16 x 11-7/16 |
| | mm | (632 x 799 x 290) |
| Gross (H x W x D) | in | 27-1/4 x 37 x 14-3/4 |
| | mm | (692 x 940 x 375) |
| Net Weight | lb (kg) | 84 (38) |
| Gross Weight | | 95 (43) |

Warranty Information



7 Year Compressor, 5 Year Parts out-of-the-box Warranty



10 Year Compressor, 10 Year Parts Warranty when registered within 60 days of installation in a residence



12 Year Compressor, 12 Year Parts Warranty when registered within 60 days of installation in a residence, and installed by a Fujitsu Elite contractor

ACCESSORIES

| | |
|------------|---------------------------------|
| UTY-TTRX | 3rd. Party Thermostat Converter |
| UTY-RNRUZ5 | Wired Remote (backlite) |
| UTY-RSRY | Simple Remote |
| UTY-LNTU | Wireless Remote |
| UTY-TFSXZ2 | Wireless Lan Adaptor |
| UTY-XWZXZG | External Connect Kit |
| UTY-XCSX | External input/output PCB |
| UTZ-VXAA | Fresh-air intake kit |
| UTZ-KXGC | Modbus Converter |



This system combination is Energy Star qualified



Indoor Unit ETL#: 3170288
 Outdoor Unit ETL#: 91987

Effective Date: 6/4/2021

Version 12LUAS1C

Due to continuous product improvements, specifications are subject to change without notice. Please log in to the Fujitsu Portal for the most up-to-date documentation <https://portal.fujitsugeneral.com>

Inverter Driven Heat Pump

12,000 BTU Single Zone Compact Cassette

FAN DATA

| | | | | |
|---------------------------|---------|--------|---------------|-----------|
| Indoor Unit Airflow Rate | Cooling | High | CFM (m3/h) | 359 (610) |
| | | Medium | | 312 (530) |
| | | Low | | 276 (470) |
| | | Quiet | | 241 (410) |
| | Heating | High | | 359 (610) |
| | | Medium | | 312 (530) |
| | | Low | | 276 (470) |
| | | Quiet | | 241 (410) |
| Outdoor Unit Airflow Rate | Cooling | | 1,171 (1,990) | |
| | Heating | | 1,089 (1,850) | |

SOUND PRESSURE

| | | | | |
|--------------|---------|--------|--------|----|
| Indoor Unit | Cooling | High | dB (A) | 37 |
| | | Medium | | 33 |
| | | Low | | 31 |
| | | Quiet | | 28 |
| | Heating | High | | 37 |
| | | Medium | | 33 |
| | | Low | | 31 |
| | | Quiet | | 28 |
| Outdoor Unit | Cooling | | 48 | |
| | Heating | | 49 | |

REFRIGERANT

| | | | |
|----------|-------|------------|--|
| Type | R410A | | |
| Charge | lb oz | 2 lb 10 oz | |
| | kg | 1,200 | |
| Oil Type | RB68 | | |

ELECTRICAL SPECIFICATIONS

| | | | |
|---------------------------|---------|-------------------|------|
| Voltage/Frequency/Phase | | 208 / 230V ~ 60Hz | |
| Voltage Range | | 187 - 253V ~ 60Hz | |
| Current | Cooling | Rated | 4.2 |
| | Heating | Rated | 6.4 |
| Maximum Operating Current | Cooling | A | 9.8 |
| | Heating | | 11.3 |
| Starting Current | | | 5.8 |
| MCA | | | 11.3 |
| Maximum Circuit Breaker | | | 15 |
| Input Power | Cooling | Rated | 0.94 |
| | | Max | 2.06 |
| | Heating | Rated | 1.44 |
| | | Max | 1.79 |
| Power Factor | Cooling | % | 97.3 |
| | Heating | % | 97.8 |

OTHER

| | | | |
|---------------------|---------------|---|---------------------|
| Moisture Removal | pints/h (L/h) | 2.5 (1.2) | |
| Energy Star | | Yes | |
| Drain hose | Material | Hard PVC | |
| Size | in (mm) | Ø1/2 (Ø13.0) [I.D.], Ø5/8 to Ø11/16 (Ø16.0 to Ø16.7) [O.D.] | |
| IDU Operation Range | Cooling | °F (°C) | 64 to 90 (18 to 32) |
| | | %RH | 80 or less |
| | Heating | °F (°C) | 60 to 88 (16 to 30) |

GRILL DATA: UTG-CCGFGA

DIMENSIONS Units: In. (mm)

Grid type grille

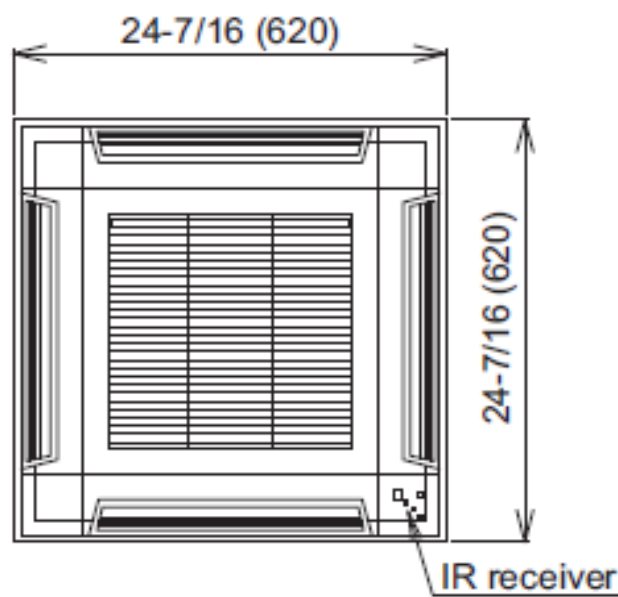

The Fujitsu logo is a worldwide trademark of Fujitsu General Limited. The Halcyon logo and name is a worldwide trademark of Fujitsu General Limited and is a registered trademark in Japan, the USA and other countries or areas. Copyright 2018 Fujitsu General America, Inc. Fujitsu's products are subject to continuous improvements. Fujitsu reserves the right to modify product design, specifications and information in this brochure without notice and without incurring any obligations.

Note: Specifications are based on the following conditions:
 Cooling: Indoor temperature of 80°F (26.7°C) DB/67°F (19.4°C) WB, and outdoor temperature of 95°F (35°C) DB/75°F (23.9°C) WB. Heating: Indoor temperature of 70°F (21.1°C) DB/60°F (15.6°C) WB, and outdoor temperature of 47°F (8.3°C) DB/43°F (6.1°C) WB. Pipe length: 25ft. (7.5m), Height difference: 0ft. (0m) (Outdoor unit – indoor unit).

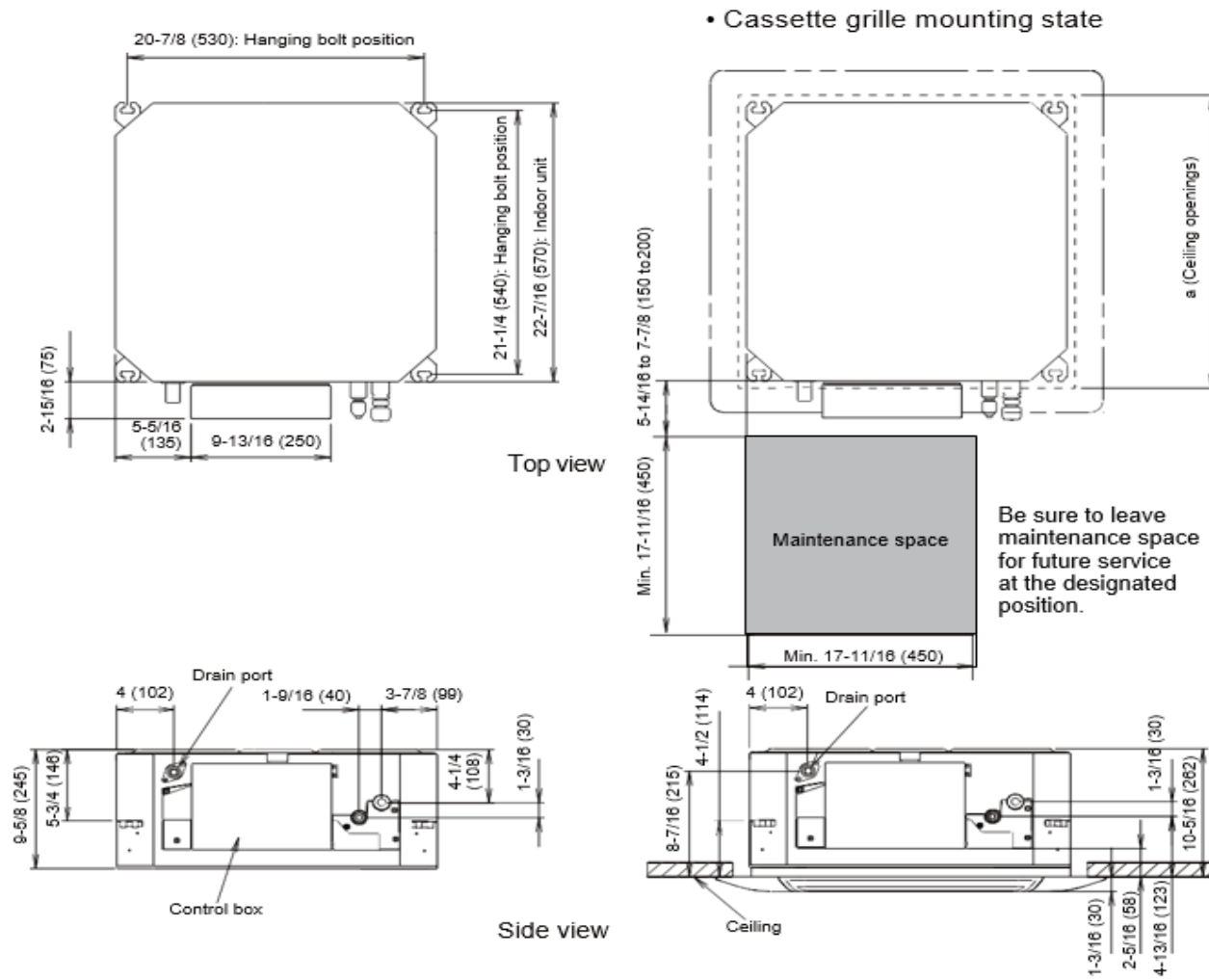

Unit: in (mm)

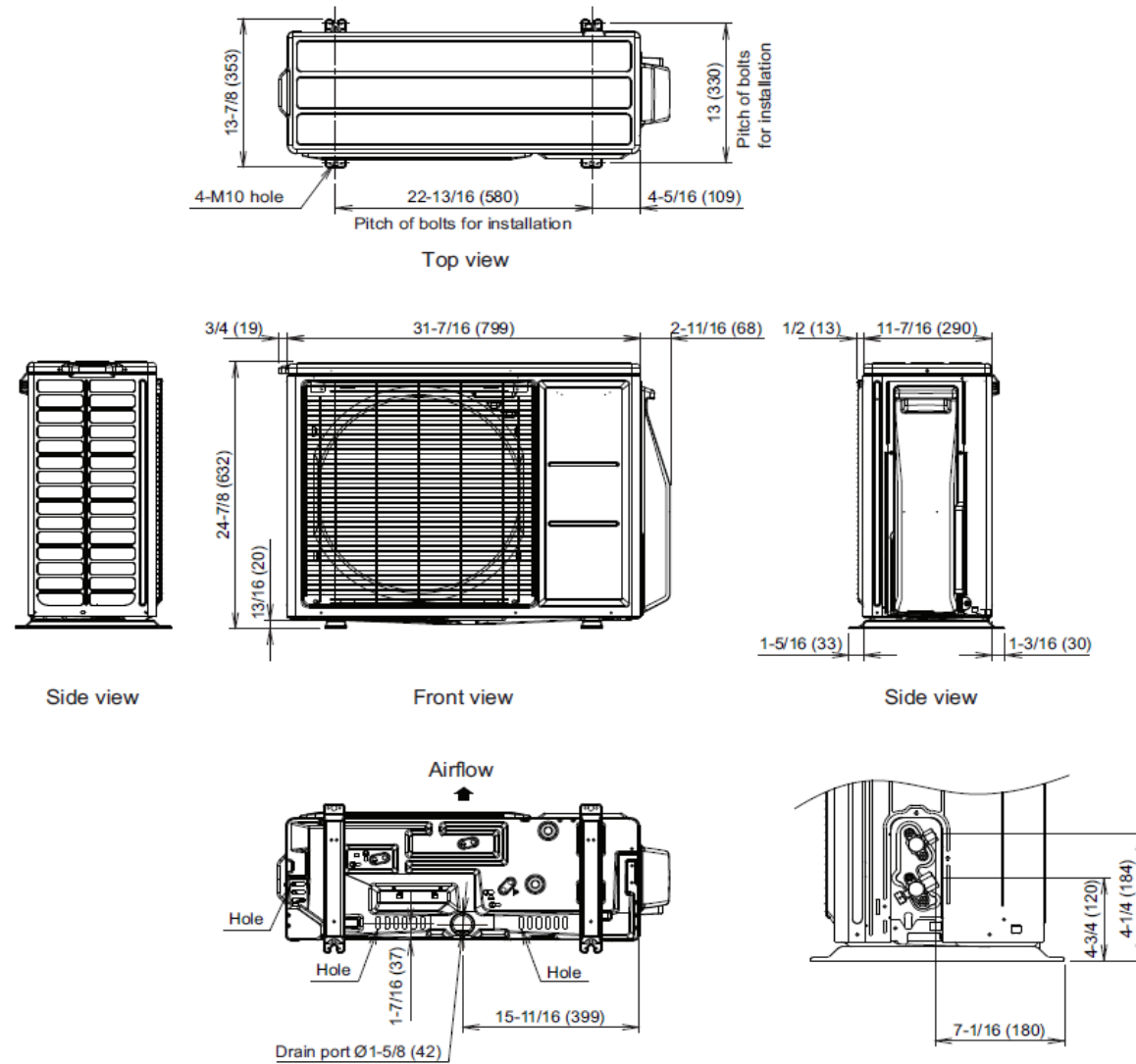

The Fujitsu logo is a worldwide trademark of Fujitsu General Limited. The Halcyon logo and name is a worldwide trademark of Fujitsu General Limited and is a registered trademark in Japan, the USA and other countries or areas. Copyright 2018 Fujitsu General America, Inc. Fujitsu's products are subject to continuous improvements. Fujitsu reserves the right to modify product design, specifications and information in this brochure without notice and without incurring any obligations.

Note: Specifications are based on the following conditions:
 Cooling: Indoor temperature of 80°F (26.7°C) DB/67°F (19.4°C) WB, and outdoor temperature of 95°F (35°C) DB/75°F (23.9°C) WB. Heating: Indoor temperature of 70°F (21.1°C) DB/60°F (15.6°C) WB, and outdoor temperature of 47°F (8.3°C) DB/43°F (6.1°C) WB. Pipe length: 25ft. (7.5m), Height difference: 0ft. (0m) (Outdoor unit – indoor unit).